



**i-mold**  
MOLDING INNOVATIONS

# TUNNEL-ANGUSS-EINSÄTZE

tunnel gate inserts  
inserti d'iniezione a tunnel

Vers. 5

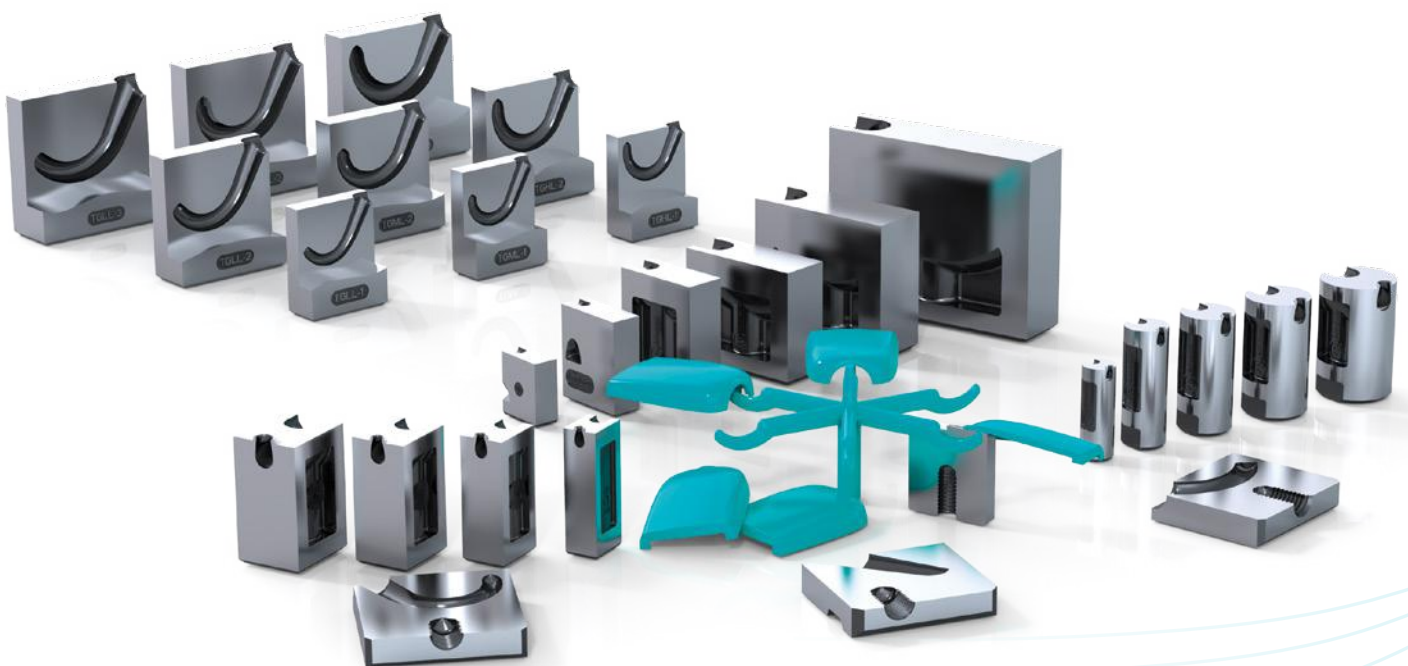

MADE  
IN  
GERMANY

## Molding Innovations made by i-mold.

### DE

i-mold "molding innovations" steht für intelligente Lösungen und innovative Produkte in der Spritzgusstechnik.

Die aus dem Hause i-mold erhältlichen Tunnel-Anguss-Einsätze sind weltweit ein Begriff für innovative Produkte mit hohem Einsparpotential für Formenbau und Spritzguss.

### EN

i-mold "molding innovations" stands for intelligent solutions and unique, innovative injection molded products.

The tunnel gate inserts from i-mold are recognized worldwide as innovative products with high cost-reducing potential for moldmakers and molders.

### IT

i-mold "molding innovations" è sinonimo di soluzioni intelligenti e di innovativi prodotti per lo stampaggio ad iniezione.

Gli inserti d'iniezione a tunnel della i-mold sono noti in tutto il mondo come prodotti innovativi con un elevato potenziale di risparmio per la costruzione di stampi e per lo stampaggio ad iniezione.

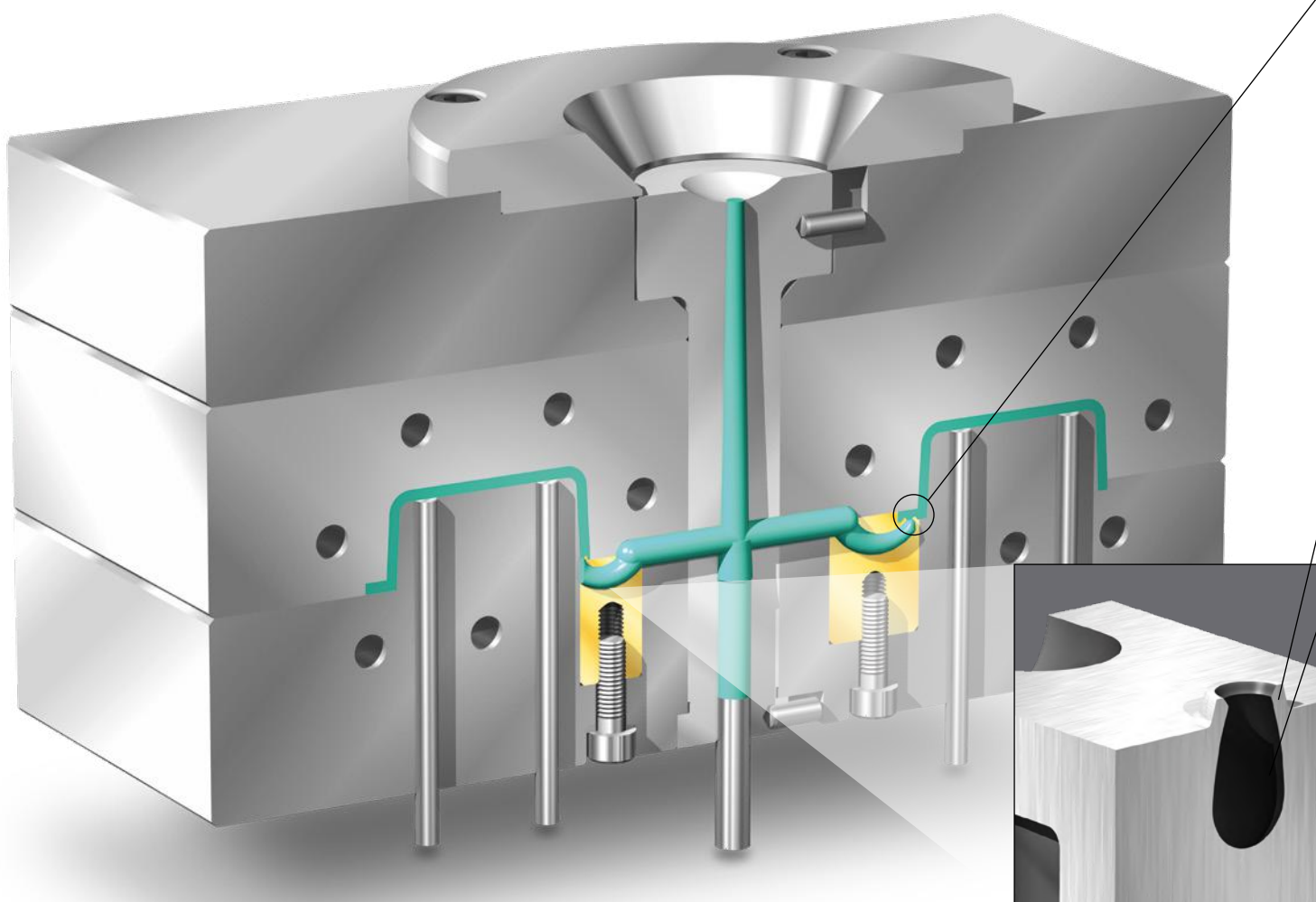

# Warum Anguss-Einsätze?

Why gate inserts?

Perché inserti d'iniezione?

## DE

- > Zeit- und Kostenersparnis durch einfache Verwendung
- > Hoch verschleißfester Warmarbeitsstahl M2 (1.3343)
- > Hohe Prozesssicherheit bei der Produktion
- > Verdeckte Angussmarkierung durch unterseitige Anspritzung
- > Einteilige Bauform ermöglicht kompakte Abmessungen
- > Viele verschiedene Varianten und unterschiedliche Größen erhältlich
- > Exakte Angusstrennung durch integrierte Abrisskante
- > Durch optimierte Kanalgeometrie für alle Kunststoffe geeignet – Füllstoffanteile (z. B. GF) bis zu 60% möglich
- > Glatte Angusskanäle und exakte Anschnittgrößen durch MIM-Verfahren

## EN

- > Time and cost reduction thanks to fast and easy application
- > Made of highly wear-resistant hot work tool steel M2 (1.3343)
- > High degree of reliability in production process
- > Invisible gate marks through underside gating
- > Single-part design for compact dimensions
- > Available in many different versions and sizes
- > Integrated cutting edge for exact sprue separation
- > Suitable for all plastics thanks to optimized feed channel geometry – up to 60% filler content (e.g. glass fibre) is possible
- > Use of MIM process ensures smooth feed channels and exact gate sizes

## IT

- > Risparmio di tempo e costi grazie al facile impiego
- > Elevata resistenza all'usura grazie al materiale sinterizzato M2 (1.3343)
- > Elevata affidabilità dei processi di produzione
- > Tracce d'iniezione invisibili grazie all'iniezione dal lato inferiore
- > La forma monoblocco consente dimensioni compatte
- > Disponibile in numerose differenti versioni e dimensioni
- > Esatta separazione della materozza grazie al bordo di distacco integrato.
- > Adatto per tutte le materie plastiche, grazie alla geometria dei canali ottimizzata – consente percentuali di riempitivo (p. es. GF) fino al 60%
- > Canali d'iniezione lisci ed esatte dimensioni dei punti d'iniezione grazie al processo MIM

**DE** Auf unserer Website halten wir für unsere Kunden sämtliche benötigten 3D-CAD-Daten zum Download bereit.

**EN** Visit our website [www.i-mold.com](http://www.i-mold.com) for complete 3D-CAD data.

**IT** I dati 3D-CAD completi sono disponibili presso la nostra website [www.i-mold.com](http://www.i-mold.com).

➔ [www.i-mold.de](http://www.i-mold.de)

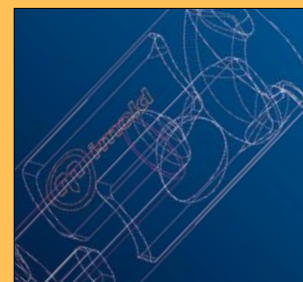

# Produktübersicht

Product overview · Panoramica prodotti

## Standard Version S2

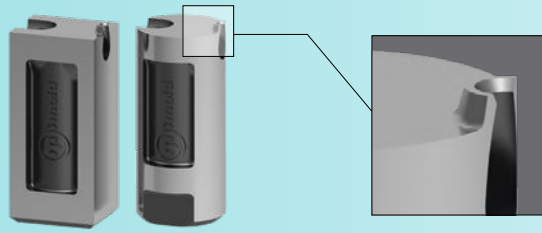

## Standard Version S1

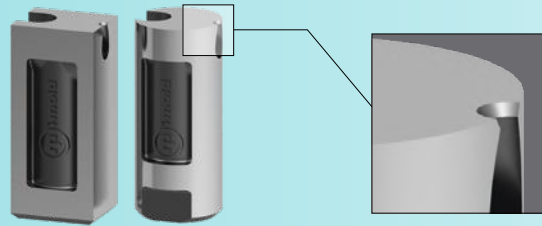

## Konturierbar

Contourable  
Contornabile

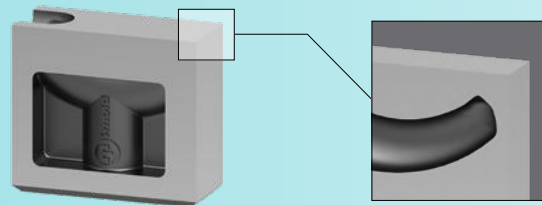

## Konturierbar

Contourable  
Contornabile

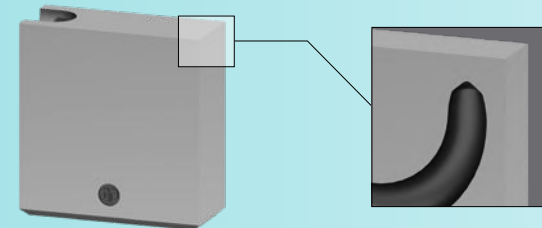

## Seitliche Anspritzung

Side gating  
Iniezione laterale

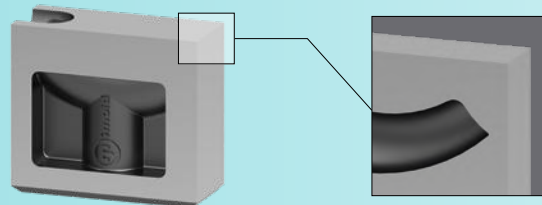

## Seitliche Anspritzung

Side gating  
Iniezione laterale

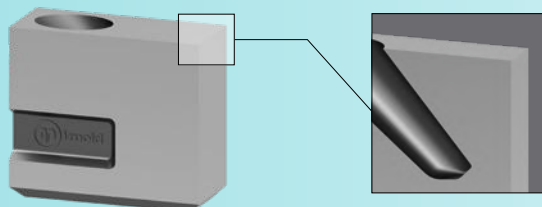

## Haltebuchse

Retaining bush  
Boccola di arresto

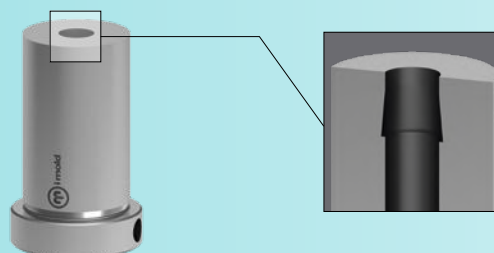

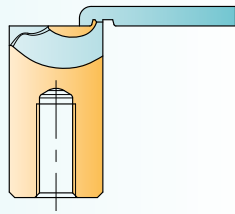

**TGR  
TGS  
S2**

**PRODUKTDDETAILS** 7-8  
Product details · Dettagli prodotto

**EINBAUANLEITUNG** 9  
Installation instructions · Istruzioni per il montaggio

**EINBAUBEISPIELE** 10  
Examples of installation · Esempi di montaggio

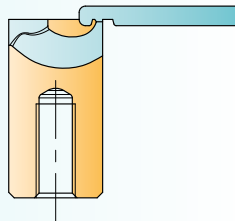

**TGR  
TGS  
S1**

**PRODUKTDDETAILS** 11-12  
Product details · Dettagli prodotto

**EINBAUANLEITUNG** 13  
Installation instructions · Istruzioni per il montaggio

**EINBAUBEISPIELE** 14  
Examples of installation · Esempi di montaggio

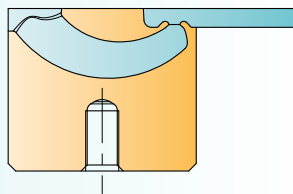

**TGC**

**PRODUKTDDETAILS** 15-16  
Product details · Dettagli prodotto

**EINBAUANLEITUNG** 37  
Installation instructions · Istruzioni per il montaggio

**EINBAUBEISPIELE** 17  
Examples of installation · Esempi di montaggio

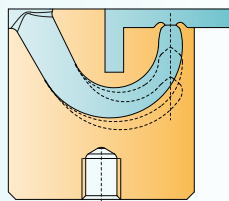

**TGLL  
TGML  
TGHL**

**PRODUKTDDETAILS** 21-23  
Product details · Dettagli prodotto

**EINBAUANLEITUNG** 37  
Installation instructions · Istruzioni per il montaggio

**EINBAUBEISPIELE** 24  
Examples of installation · Esempi di montaggio

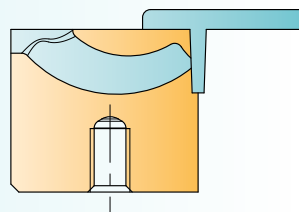

**SGC**

**PRODUKTDDETAILS** 25-26  
Product details · Dettagli prodotto

**EINBAUANLEITUNG** 27  
Installation instructions · Istruzioni per il montaggio

**EINBAUBEISPIELE** 28  
Examples of installation · Esempi di montaggio

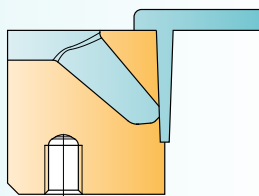

**TPS**

**PRODUKTDDETAILS** 29-30  
Product details · Dettagli prodotto

**EINBAUANLEITUNG** 31  
Installation instructions · Istruzioni per il montaggio

**EINBAUBEISPIELE** 32  
Examples of installation · Esempi di montaggio

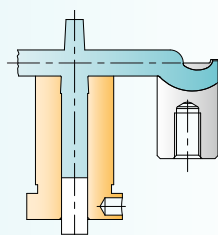

**PRODUKTDDETAILS** 33  
Product details · Dettagli prodotto

**ERGÄNZENDE TIPPS** 34-39  
Supplementary tips · Consigli supplementari

# Technische Information

Technical information · Informazioni tecniche

## Viskositätsdiagramm · Viscosity graph · Diagramma di viscosità

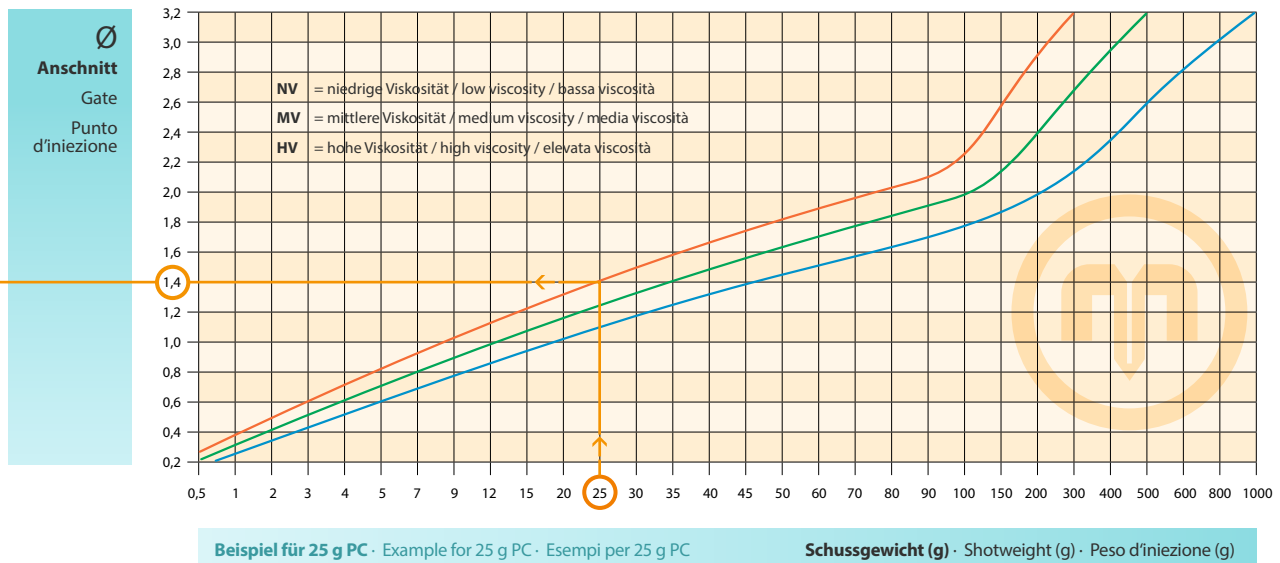

### DE

**Achtung:** Bei Verwendung von gefüllten Kunststoffen (Glasfaser, Kohlefaser, etc.), den mit der Tabelle ermittelten Anschnittdurchmesser um 20 % vergrößern!

Die empfohlenen Schussgewichte und Anschnittdurchmesser sind nur Richtwerte. Geometrie des Teiles, Werkzeugkonzept, Kunststofftyp und Füllstoffe müssen individuell berücksichtigt werden.

### EN

**Caution:** When using filled plastics (glass fibres, carbon fibres etc.) you should increase the computed gate diameter by 20%.

The recommended shotweights and gate diameters are guide values only! Please also take into account such individual parameters as part geometry, mold design, type of plastic and fillers.

### IT

**Attenzione:** In caso di impiego di plastica caricata (fibre di vetro, di carbonio ecc.) è necessario aumentare del 20% il diametro d'iniezione calcolato in base alla tabella!

I pesi ed i diametri d'iniezione consigliati sono soltanto valori indicativi. La geometria del pezzo, il sistema di stampo, il tipo di plastica ed i riempitivi devono essere considerati individualmente.

## Anschnittdurchmesser · Gate Diameter · Diametro del punto d'iniezione

Ø	Querschnittsfläche in mm <sup>2</sup> Cross-sectional area mm <sup>2</sup> Superficie trasversale mm <sup>2</sup>	Gate Diameter					
		TGS/TGR	TGC-XS SGC-XS	TGC-S SGC-S TPS-S	TGC-1 SGC-1 TPS-1 TGLL-1 TGML-1 TGHL-1	TGC-2 SGC-2 TPS-2 TGLL-2 TGML-2 TGHL-2	TGC-3 / -4 SGC-3 / -4 TPS-3 TGLL-3 TGML-3 TGHL-3
0,4	0,13	0,6	0,4	0,4	0,6	0,8	
0,6	0,28	0,8	0,6	0,6	0,8	1,0	
0,8	0,50	1,2	0,8	0,8	1,0	1,2	
1,0	0,78	1,6		1,0	1,2	1,4	
1,2	1,13	2,0		1,2	1,4	1,6	
1,4	1,54					1,8	
1,6	2,01	2,4					
1,8	2,54	2,8					
2,0	3,14						
2,2	3,8						
2,4	4,52						
2,6	5,31						
2,8	6,15						
3,0	7,07						
3,2	8,04						
:	:						
4,5	18,8						

**Legend for Gate Diameter:**  
 TGR / TGS / TGC / TGLL / TGML / TGHL (Blue)  
 SGC (Orange)  
 TPS (Grey)

**Rectangular Gate Diameters:**  
 0,5 x (4,5)  
 0,6 x (4,6)  
 0,7 x (4,7)  
 0,8 x (4,8)  
 0,9 x (4,9)  
 1,0 x (5,0)  
 1,1 x (5,1)  
 1,2 x (5,2)  
 1,3 x (5,3)  
 1,4 x (5,4)  
 1,5 x (5,5)  
 4,5

# TGR TGS S2

mit Kalotte  
with vestige  
con calotta

TGR / TGS S2

Geeignet für alle Kunststoffe · Suitable for all plastics · Adatto per ogni tipo di plastica

- DE** > für flache Trennungen, inkl. Kalotte mit integrierter Abrisskante  
> direkt einsetzbar! Keine Anpassungen erforderlich  
> in Härte 60 HRC erhältlich  
> erhältlich in runder (TGR) und eckiger (TGS) Ausführung

- EN** > for flat parting surfaces, including vestige with integrated cutting edge  
> ready to use! No adjustments necessary  
> available with hardness 60 HRC  
> available in round (TGR) and square (TGS) versions

- IT** > per separazioni piatte, inclusa calotta con bordo di distacco integrato  
> impiego diretto! Non sono necessari adattamenti  
> disponibile in durezza 60 HRC  
> disponibile in versione tonda (TGR) e squadrata (TGS)

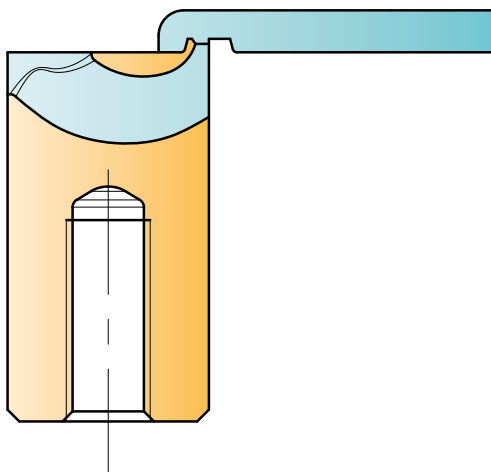

	TGR 6	TGR/TGS 8	TGR/TGS 10	TGR/TGS 12	TGR/TGS 14
 Anschnitt / gate point / punto d'iniezione	0.6	0,6 / 0,8	0,8 / 1,2 / 1,6	1,2 / 1,6 / 2,0	1,6 / 2,0 / 2,4 / 2,8
Ø Kanal / runner / canale	2.5	3	4	5	6
<b>max. Schussgewichte (g) · max. shotweight (g) · pesi d'iniezione max. (g)</b>					
<b>NV</b>	3	5	30	50	200
<b>MV</b>	2	4	20	35	120
<b>HV</b>	1	3	12	25	75

NV = niedrige Viskosität / low viscosity / bassa viscosità  
MV = mittlere Viskosität / medium viscosity / media viscosità  
HV = hohe Viskosität / high viscosity / elevata viscosità

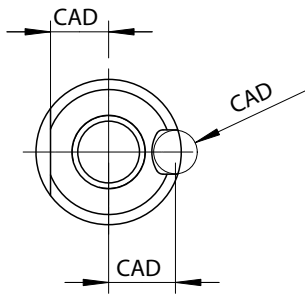

**Mögliche Verdrehsicherung**  
Anti-rotation locking possibility  
Possibilità di protezione antitorsione

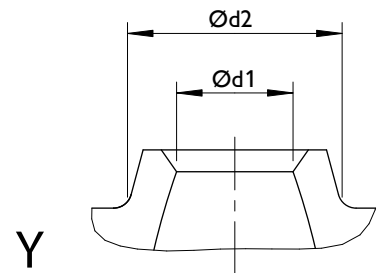
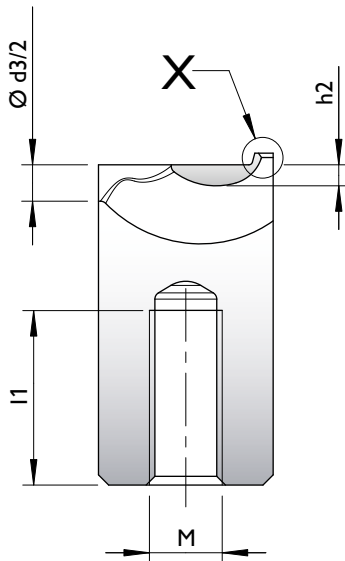
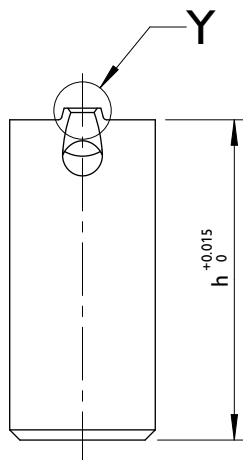
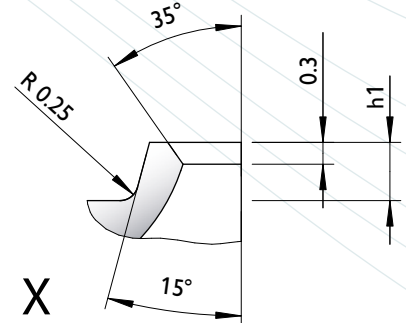

TGS	Typ	b	b1	d1	d2	d3	h	h1	h2	l1	l2	M	Version
	TGS8	8	6	0.6	1.9	3	22.0	0.6	1.1	13	3.25	4	S2
	TGS10	10	8	0.8	2.1	4	22.0	0.8	1.2	12	4	5	S2
				1.2	2.6								
TGS12	12	10	1.2	2.6	5	22.0	0.8	1.40	11	5	5	S2	
			1.6	3.0									
			2.0	3.4									
TGS14	14	12	1.6	3.0	6	22.0	0.8	1.6	10	6	6	S2	
			2.0	3.4									
			2.4	3.8									
			2.8	4.2									

TGR	Typ	d	d1	d2	d3	h	h1	h2	l1	l2	M	Version
	TGR6	6	0.6	1.9	2.5	17.0	0.6	0.8	10	2.5	4	S2
	TGR8	8	0.6	1.9	3	22.0	0.6	1.1	13	3.25	4	S2
			0.8	2.1								
TGR10	10	0.8	2.2	4	22.0	0.8	1.2	12	4	5	S2	
		1.2	2.6									
		1.6	3.0									
TGR12	12	1.2	2.6	5	22.0	0.8	1.4	11	5	5	S2	
		1.6	3.0									
		2.0	3.4									
TGR14	14	1.6	3.0	6	22.0	0.8	1.6	10	6	6	S2	
		2.0	3.4									
		2.4	3.8									
		2.8	4.2									

➔ Beispiel Bestellbezeichnung · Example of order specification · Esempio codice di ordinazione: **TGR6-06-S2**



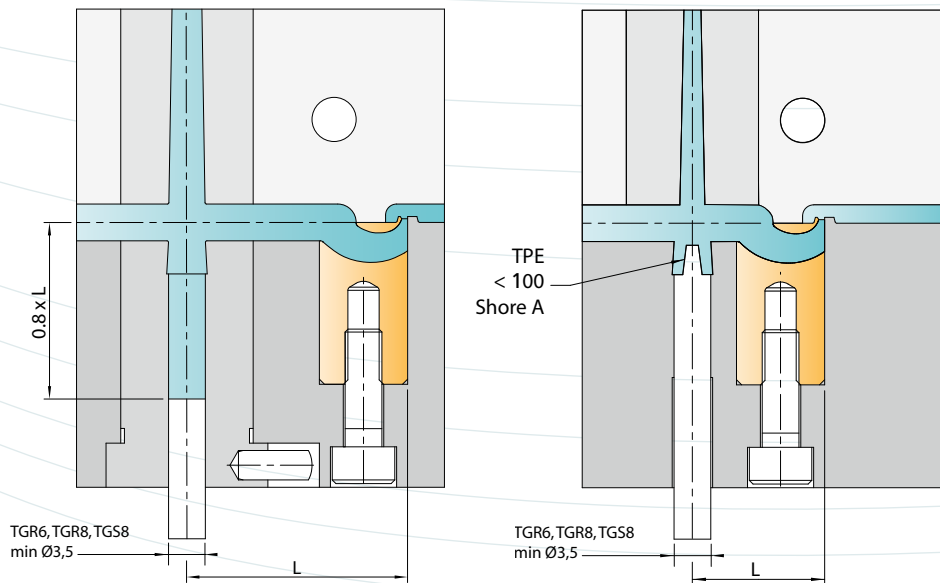

- DE Thermoplastische Elastomere (TPE)**
  - > Kleine Shorehärte = geringeres Abstandsmaß L
  - > Zentrierzapfen verwenden
  - > Shorehärte max. 100 Shore A
- EN Thermoplastic elastomers (TPE)**
  - > Low Shore hardness = shorter distance L
  - > Use centring pin
  - > Max. hardness 100 Shore A
- IT Elastomeri termoplastici (TPE)**
  - > Bassa durezza Shore = distanza L più ridotta
  - > Utilizzare un perno di guida
  - > Durezza: max. 100 Shore A

**Diagramm für Abstandsmaß L** · Table for distance L · Diagramma per la distanza L

	Materialart · Material type · Tipo di materiale			
	TPE, TPU etc.	PE, PP, PET etc.	PC, ABS, PA, POM, HI-PC, etc.	PA+GF, PC, SAN, PMMA, etc.
<b>TGR 6</b>	9-12	12-18	15-22	18-25
<b>TGR/TGS 8</b>	11-14	15-22	19-27	23-30
<b>TGR/TGS 10</b>	15-18	19-27	24-33	28-36
<b>TGR/TGS 12</b>	18-22	22-30	27-36	32-40
<b>TGR/TGS 14</b>	20-25	25-33	30-37	35-43

**Empfehlungen** · Recommendations · Consigli

<b>Gegenkalotte</b> Companion vestige / Controcalotta	<b>Flache Teile</b> Flat parts / Pezzi piatti
--	--

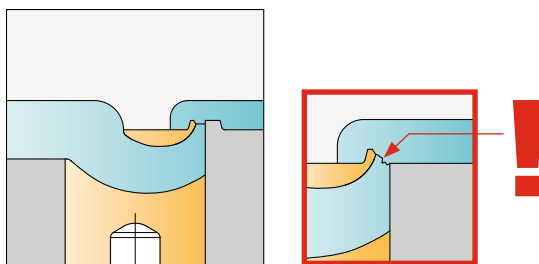

**DE** Um ein optimales Abreißen des Anschnittes zu gewährleisten (insbesondere bei flachen Teilen) empfehlen wir im Bereich der Kalotte mit Abrisskante eine Gegenkalotte vorzusehen. Diese gewährleistet ein Abreißen parallel zur Trennebene. Besonders bei Materialien zu empfehlen, die zu Fadenzug neigen.

**EN** For optimum degating (especially of flat parts), we recommend the use of a companion vestige supplementing the vestige with cutting edge. This configuration will ensure that the part is separated from the runner flush with the parting line. Users will find this particularly advantageous in cases where materials are susceptible to stringing.

**IT** Per garantire un ottimale distacco del punto d'iniezione (soprattutto con pezzi piatti) è consigliabile l'impiego di un una controcalotta nella zona della calotta con bordo di distacco. In questo modo si garantisce un distacco parallelo alla linea di giunzione. Questo metodo è consigliabile soprattutto per i materiali che tendono a sfilacciarsi.

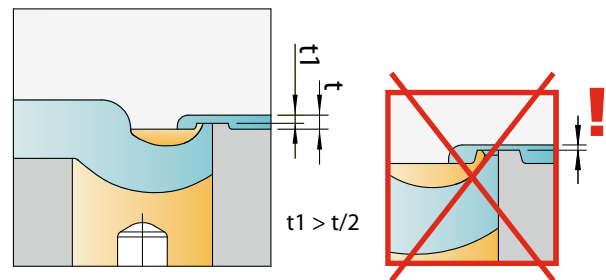

**DE** Bei sehr dünnen Teilen muss die Kalotte abgeschliffen werden. ( $t_1 > t_2$ )

**EN** If the molded part is very thin, the calotte must be ground down. ( $t_1 > t_2$ )

**IT** Per la realizzazione di pezzi molto sottili è necessario rettificare la calotta. ( $t_1 > t_2$ )

# Einbaubeispiele

Examples of installation · Esempi di montaggio

**unter Wand** / under wall / sotto parete

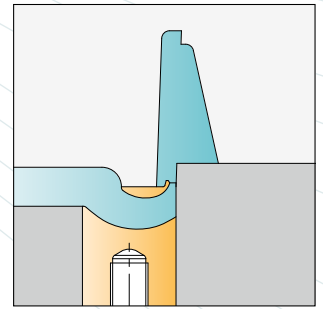
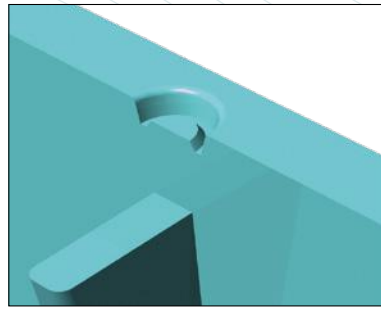
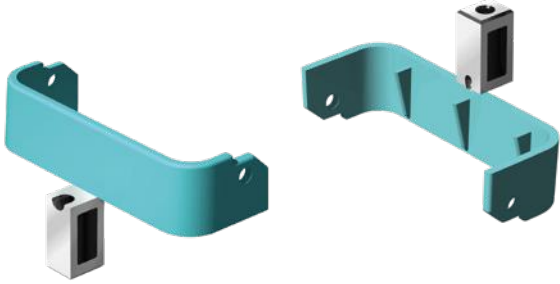

**mit Fließhilfe** / with flow promoter / con fluidificante

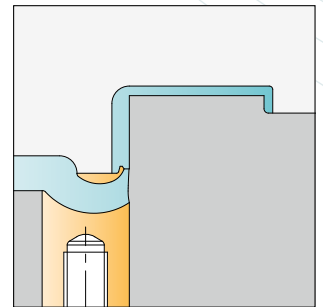
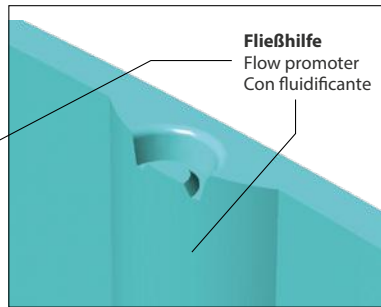
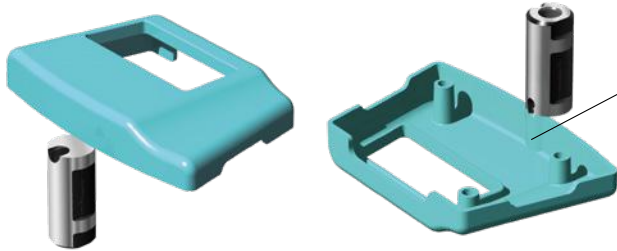

**angepasst an Kunststoffteil** / adapted to part / adattato al pezzo

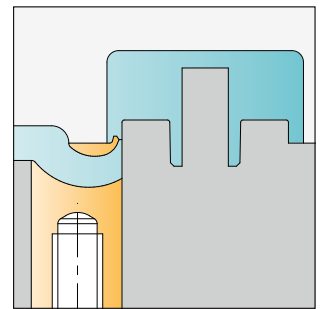
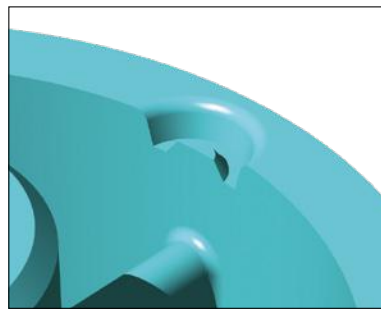
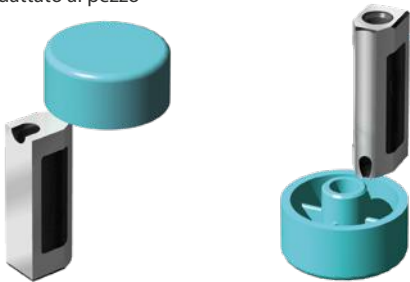

**flaches Teil mit Gegenkalotte – Einbau in Düsenseite**

flat part with companion vestige – installation in fixed half of the mold  
pezzo piatto con controcalotta – montaggio nel lato ugello

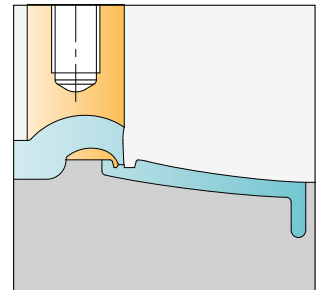
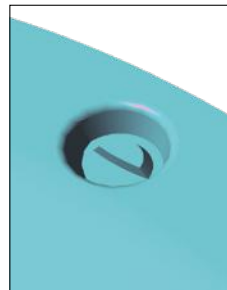

**flaches Teil ohne Gegenkalotte**

flat part without companion vestige  
pezzo piatto senza controcalotta

**DE** wenn kein 100%iger Abriss gefordert ist oder verstärkte Kunststoffe verwendet werden, kann bei flachen Teilen ohne Gegenkalotte gearbeitet werden. (siehe Seite 9).

**EN** If a 100% clean separation of the sprue is not necessary or if reinforced plastics are being processed, the use of a companion vestige may be waived when molding flat parts. (see page 9).

**IT** la controcalotta non è necessaria se non è richiesto un distacco al 100% oppure se vengono impiegate plastiche rinforzate. (Vedasi pagina 9).

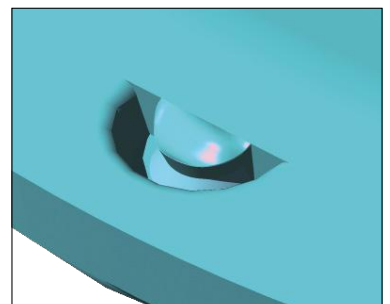

# TGR TGS S1

mit Aufmaß  
with machining allowance  
con tolleranza dimensionale

Geeignet für alle Kunststoffe · Suitable for all plastics · Adatto per ogni tipo di plastica

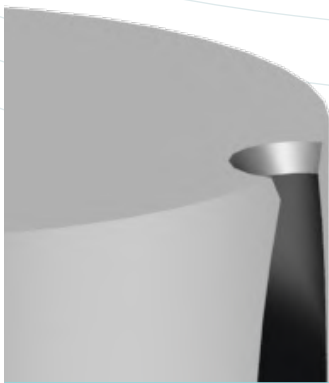

- DE** > mit Aufmaß an der oberen Fläche  
> leichte Konturierungen möglich  
> gleiche Eigenschaften wie Version S2  
> erhältlich in runder (TGR) und eckiger (TGS) Ausführung

- EN** > with machining allowance on upper surface  
> slight contourings possible  
> same properties as version S2  
> available in round (TGR) and square (TGS) versions

- IT** > con tolleranza dimensionale sulla superficie superiore  
> consente semplici contornature  
> caratteristiche identiche a quelle della versione S2  
> disponibile in versione tonda (TGR) e squadrata (TGS)

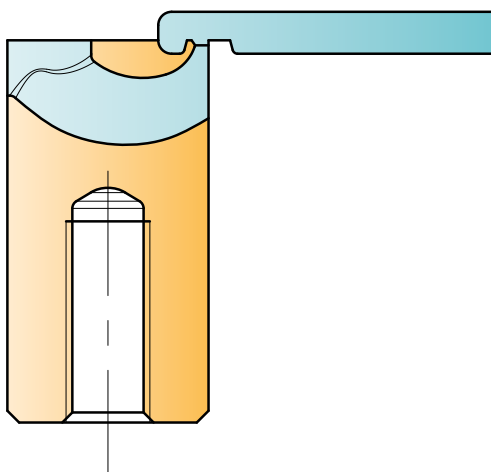

	TGR 6	TGR/TGS 8	TGR/TGS 10	TGR/TGS 12	TGR/TGS 14
 Anschnitt / gate point / punto d'iniezione	0.6	0,6 / 0,8	0,8 / 1,2 / 1,6	1,2 / 1,6 / 2,0	1,6 / 2,0 / 2,4 / 2,8
Ø Kanal / runner / canale	2.5	3	4	5	6
<b>max. Schussgewichte (g) · max. shotweight (g) · pesi d'iniezione max. (g)</b>					
<b>NV</b>	3	5	30	50	200
<b>MV</b>	2	4	20	35	120
<b>HV</b>	1	3	12	25	75

NV = niedrige Viskosität / low viscosity / bassa viscosità  
MV = mittlere Viskosität / medium viscosity / media viscosità  
HV = hohe Viskosität / high viscosity / elevata viscosità

TGR / TGS S1

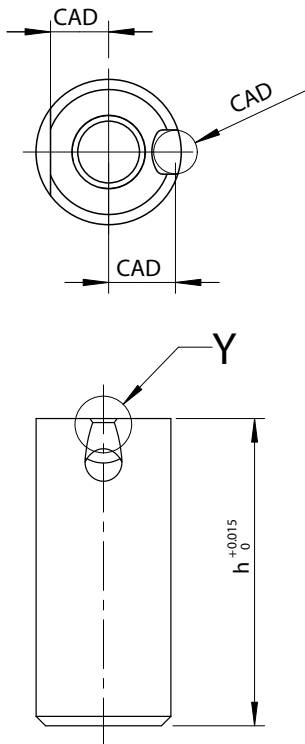

**Mögliche Verdrehsicherung**  
Anti-rotation locking possibility  
Possibilità di protezione antitorsione

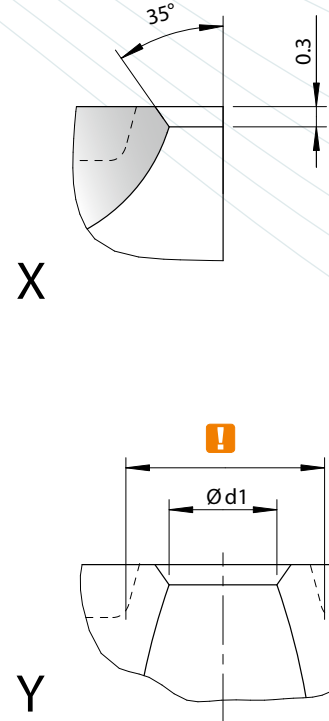
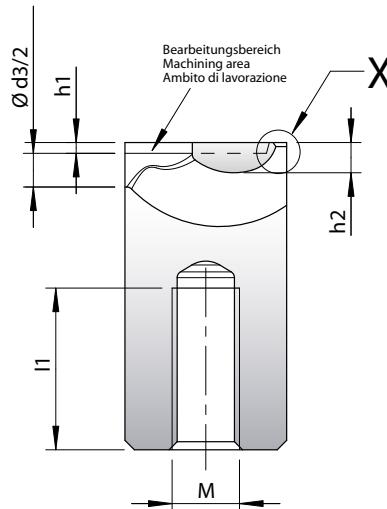

**Mindestgröße der Kalotte wie bei S2**  
Minimum size of vestige same as version S2  
Dimensioni minime della calotta come per la versione S2

TGS	Typ	b	b1	d1	d3	h	h1	h2	l1	l2	M	Version
	TGS8	8	6	0.6	3	22.6	0.6	1.7	13	3.25	4	S1
				0.8								
	TGS10	10	8	0.8	4	22.8	0.8	2.0	12	4	5	S1
				1.2								
				1.6								
	TGS12	12	10	1.2	5	22.8	0.8	2.2	11	5	5	S1
				1.6								
				2.0								
	TGS14	14	12	1.6	6	22.8	0.8	2.4	10	6	6	S1
				2.0								
				2.4								
				2.8								

TGR	Typ	d	d1	d3	h	h1	h2	l1	l2	M	Version	
	TGR6	6	0.6	2.5	17.6	0.6	1.4	10	2.5	4	S1	
	TGR8	8	0.6	3	22.6	0.6	1.7	13	3.25	4	S1	
				0.8								
	TGR10	10	0.8	4	22.8	0.8	2.0	12	4	5	S1	
				1.2								
				1.6								
	TGR12	12	1.2	5	22.8	0.8	2.2	11	5	5	S1	
				1.6								
				2.0								
	TGR14	14	1.6	6	22.8	0.8	2.4	10	6	6	S1	
				2.0								
				2.4								
			2.8									



Beispiel Bestellbezeichnung · Example of order specification · Esempio codice di ordinazione: **TGR6-06-S1**

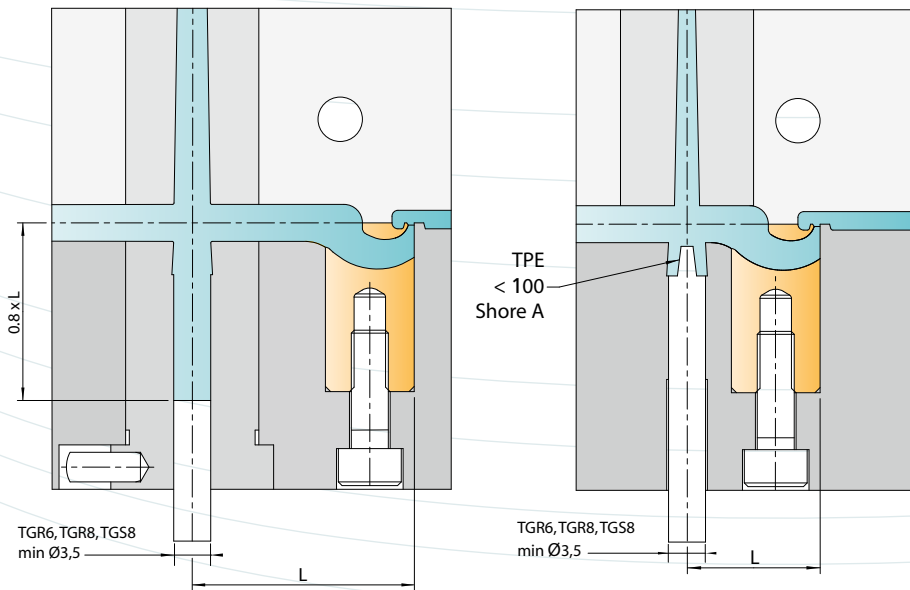

**DE Thermoplastische Elastomere (TPE)**

- > Kleine Shorehärte = geringeres Abstandsmaß L
- > Zentrierzapfen verwenden
- > Shorehärte max. 100 Shore A

**EN Thermoplastic elastomers (TPE)**

- > Low Shore hardness = shorter distance L
- > Use centring pin
- > Max. hardness 100 Shore A

**IT Elastomeri termoplastici (TPE)**

- > Bassa durezza Shore = distanza L più ridotta
- > Utilizzare un perno di guida
- > Durezza: max. 100 Shore A

TGR / TGS S1

Diagramm für Abstandsmaß L · Table for distance L · Diagramma per la distanza L

	Materialart · Material type · Tipo di materiale			
	TPE, TPU etc.	PE, PP, PET etc.	PC, ABS, PA, POM, HI-PC, etc.	PA+GF, PC, SAN, PMMA etc.
TGR 6	9-12	12-18	15-22	18-25
TGR/TGS 8	11-14	15-22	19-27	23-30
TGR/TGS 10	15-18	19-27	24-33	28-36
TGR/TGS 12	18-22	22-30	27-36	32-40
TGR/TGS 14	20-25	25-33	30-37	35-43

**Empfehlungen · Recommendations · Consigli**

**Gegenkalotte**  
Companion vestige / Controcalotta

**Flache Teile**  
Flat parts / Pezzi piatti

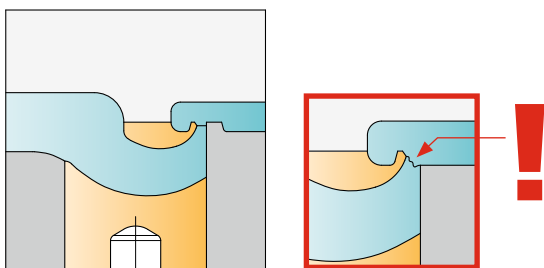

**DE** Um ein optimales Abreißen des Anschnittes zu gewährleisten (insbesondere bei flachen Teilen) empfehlen wir im Bereich der Kalotte mit Abrisskante eine Gegenkalotte vorzusehen. Diese gewährleistet ein Abreißen parallel zur Trennebene. Besonders bei Materialien zu empfehlen, die zu Fadenzug neigen.

**EN** For optimum degating (especially of flat parts), we recommend the use of a companion vestige supplementing the vestige with cutting edge. This configuration will ensure that the part is separated from the runner flush with the parting line. Users will find this particularly advantageous in cases where materials are susceptible to stringing.

**IT** Per garantire un ottimale distacco del punto d'iniezione (soprattutto con pezzi piatti) è consigliabile l'impiego di una controcalotta nella zona della calotta con bordo di distacco. In questo modo si garantisce un distacco parallelo alla linea di giunzione. Questo metodo è consigliabile soprattutto per i materiali che tendono a sfilacciarsi.

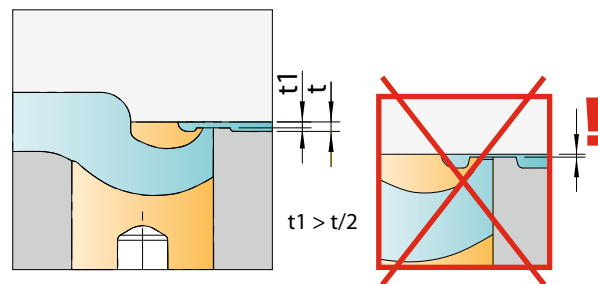

**DE** Bei sehr dünnen Teilen muss die Kalotte abgeschliffen werden. ( $t_1 > t/2$ )

**EN** If the molded part is very thin, the calotte must be ground down. ( $t_1 > t/2$ )

**IT** Per la realizzazione di pezzi molto sottili è necessario rettificare la calotta. ( $t_1 > t/2$ )

# Einbaubeispiele

Examples of installation · Esempi di montaggio

**abgerundete Kante** / rounded edge / bordo arrotondato

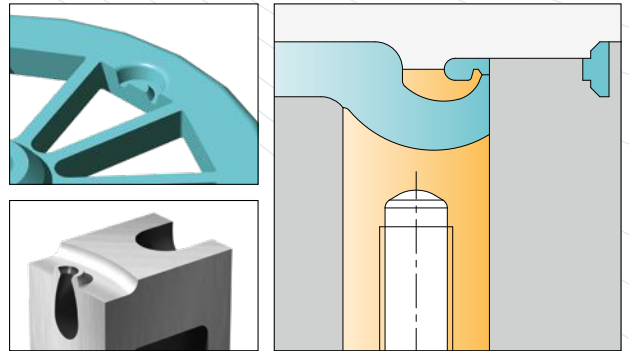

**mit Fließhilfe** / with flow promoter / con fluidificante

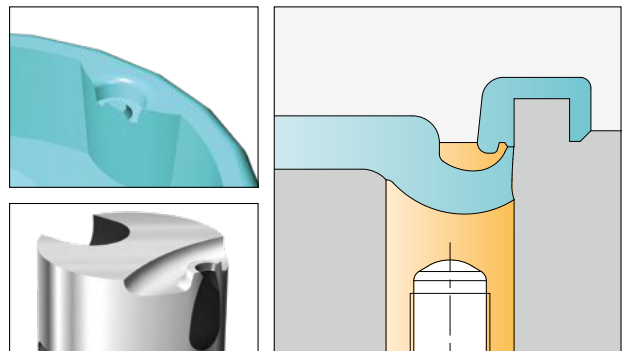
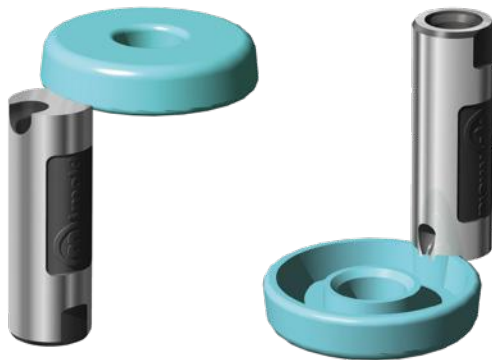

**gewölbte Trennung** / rounded separation / separazione bombata

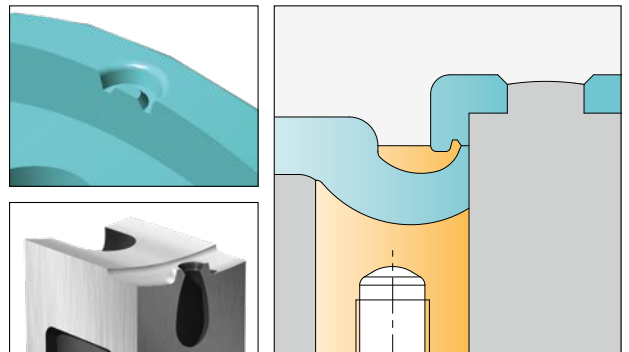

**flach mit Gegenkalotte** / flat, with companion vestige / piatto, con controcalotta

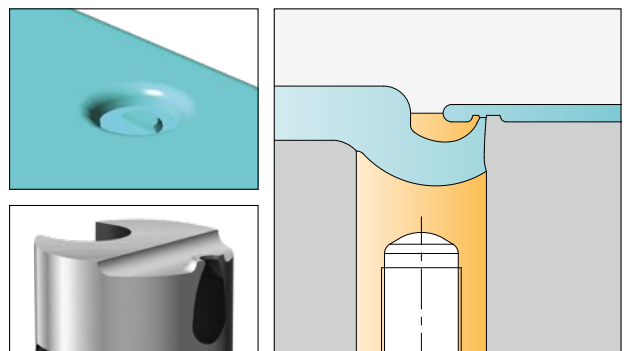
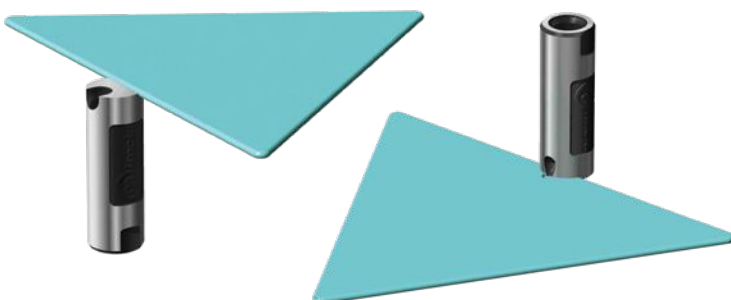

# TGC

konturierbar  
contourable  
contornabile

Optimal für spröde und verstärkte Kunststoffe · Perfect for rigid and enforced plastics · Adatto per ogni tipo di plastica

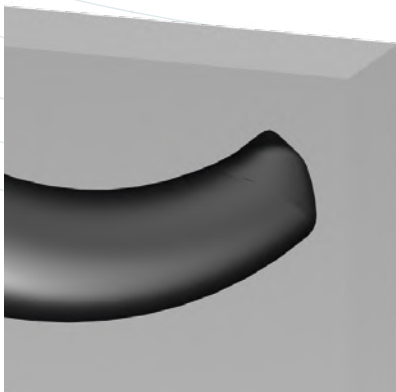

**DE** > für Konturierungen bis zu 10mm  
> individuell anpassbar  
> in 2 Härteklassen (60 HRC / 40 HRC) erhältlich

**EN** > for contouring up to 10mm  
> individually adjustable  
> available in 2 degrees of hardness (60 HRC / 40 HRC)

**IT** > per contornature fino a 10mm  
> adattamento individuale  
> disponibile in 2 differenti durezza (60 HRC / 40 HRC)

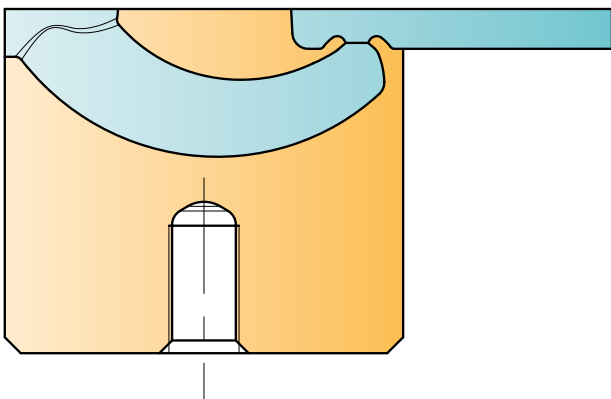

TGC



	TGC-XS	TGC-S	TGC-1	TGC-2	TGC-3	TGC-4
max. Konturtiefe / max. contour depth / max. profondità di contornatura	1	2	2	3	5	10
∅ Anschnitt / gate point / punto d'iniezione	0,4 - 0,6	0,4 - 0,8	0,6 - 1,2	0,8 - 1,8	0,5x4,5 - 1,5x5,5	0,5x4,5 - 1,5x5,5
∅ Kanal / runner / canale	2,5	2,5	4	6	8	8

	max. Schussgewichte (g) · max. shotweight (g) · pesi d'iniezione max. (g)					
<b>NV</b>	5	12	35	120	1000	1000
<b>MV</b>	4	7	25	75	500	500
<b>HV</b>	3	5	15	50	300	300

NV = niedrige Viskosität / low viscosity / bassa viscosità  
MV = mittlere Viskosität / medium viscosity / media viscosità  
HV = hohe Viskosität / high viscosity / elevata viscosità

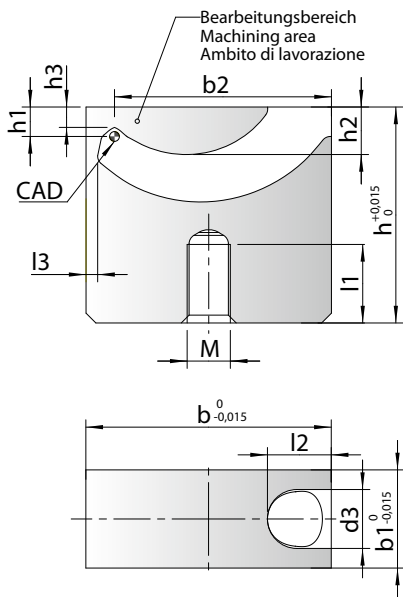

## TGC-XS / TGC-S

### Befestigungsmöglichkeiten

Mounting possibilities  
Possibilità di fissaggio

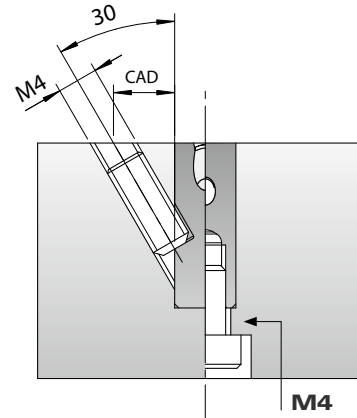

Typ	b	b1	b2	d3	h	h1	h2	h3	I1	I2	I3	M	HRC
TGC-XS	10	5	8.5	2.5	12	1	1.9	0.6	5	3.2	0.7	4	Version U = 40 HRC Version H = 60 HRC
TGC-S	15	6	13.3	2.5	18	2	3.5	1.5	8	4	0.9	4	
TGC-1	18	8	16	4	22	2	3.5	1.3	9	5.2	0.9	5	
TGC-2	25	10	22.1	6	22	3	4.8	2.1	8	6.5	1.2	5	
TGC-3	30	12	26.9	8	27	5	7.5	4.1	9	7	1.2	6	
TGC-4	45	12	41.2	8	36	10	16.7	9.1	8	9.6	1.8	6	

➔ Beispiel Bestellbezeichnung · Example of order specification · Esempio codice di ordinazione: **TGC-XS-U**

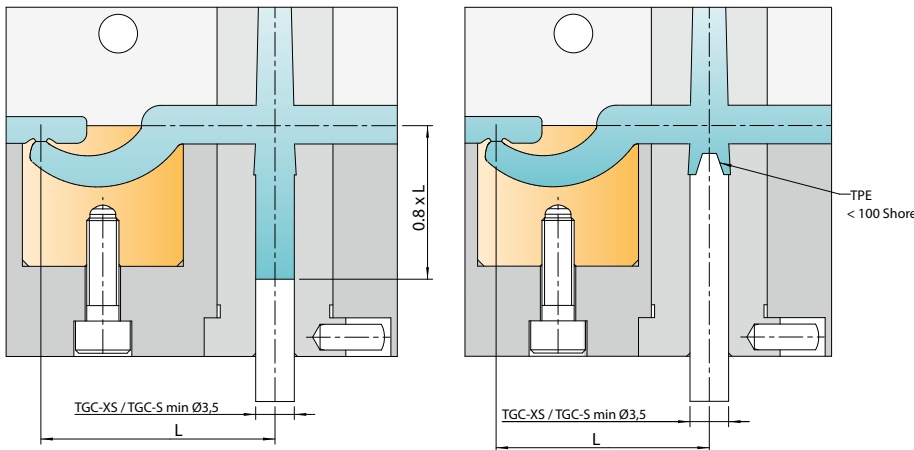

- DE Thermoplastische Elastomere (TPE)**
  - > Kleine Shorehärte = geringeres Abstandsmaß L
  - > Zentrierzapfen verwenden
  - > Shorehärte max. 100 Shore A
- EN Thermoplastic elastomers (TPE)**
  - > Low Shore hardness = shorter distance L
  - > Use centring pin
  - > Max. hardness 100 Shore A
- IT Elastomeri termoplastici (TPE)**
  - > Bassa durezza Shore = distanza L più ridotta
  - > Utilizzare un perno di guida
  - > Durezza: max. 100 Shore A

### Diagramm für Abstandsmaß L · Table for distance L · Diagramma per la distanza L

	Materialart · Material type · Tipo di materiale			
	TPE, TPU etc.	PE, PP, PET etc.	PC, ABS, PA, POM, HI-PC, etc.	PA+GF, PC, SAN, PMMA etc.
TGC-XS	12-16	13-20	16-23	22-29
TGC-S	16-21	18-25	21-28	27-34
TGC-1	21-26	26-34	31-39	36-45
TGC-2	28-33	31-39	36-44	41-50
TGC-3	33-38	38-48	43-53	48-58
TGC-4	48-53	53-63	58-68	?

➔ Kalottengestaltung > siehe ergänzende Tipps (Seite 36) · Vestige design > see additional tips (page 36) · Design della calotta à vedi dati aggiuntivi (pagina 36)



# Einbaubeispiele

Examples of installation · Esempi di montaggio

**unter Flächen** / under surface / sotto superficie

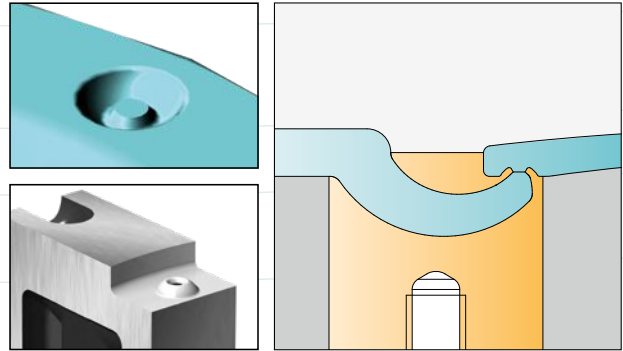
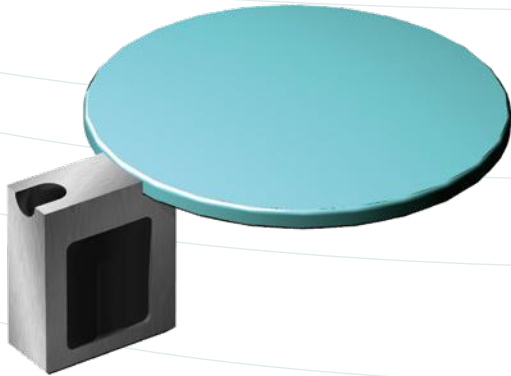

**unter gewölbter Fläche** / under rounded surface / sotto superficie bombata

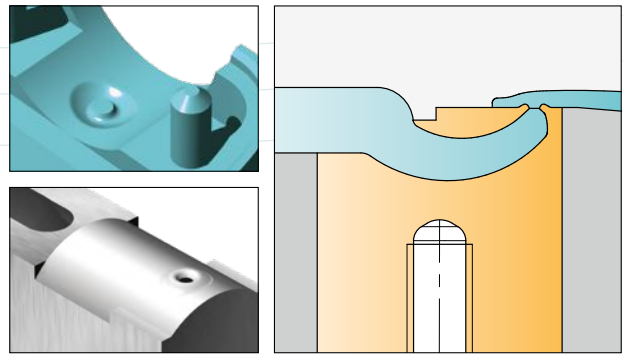
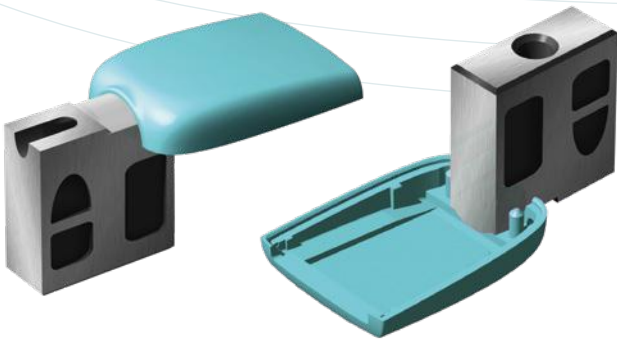

**halbierter Anspritzpunkt** / half gate point / punto d'iniezione dimezzato

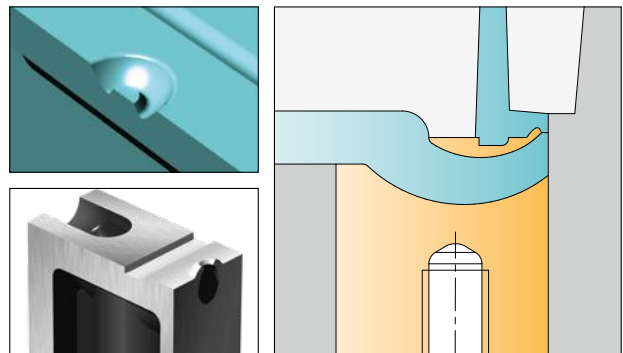
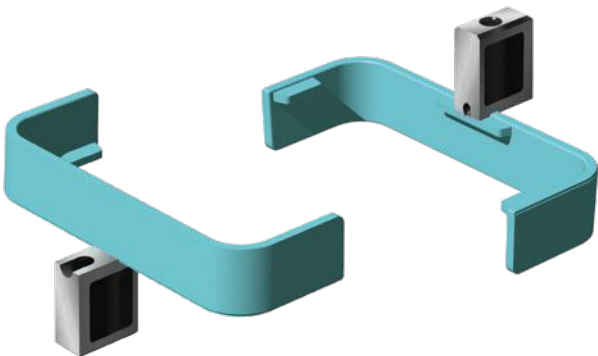

**Anspritzung auf Schräge** / angled gating / iniezione su superficie obliqua

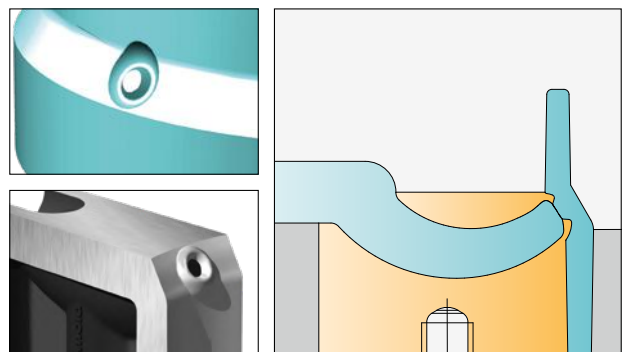
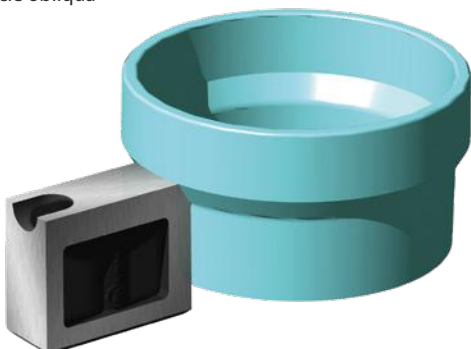

TGC

# TGLL

konturierbar  
contourable  
contornabile

Für spröde und verstärkte Kunststoffe bedingt geeignet · Restrictedly suitable for rigid and reinforced plastics ·  
Adatto esclusivamente per plastiche rigide e rinforzate



**DE** > platzsparender, konturierbarer Angusseinsatz für Anspritzung unterhalb der Formtrennung  
> hoch verschleißfester Warmarbeitsstahl M2 (1.3343) 54+2 HRC

**EN** > Space-saving, contourable Tunnel Gate insert for gating below the parting line  
> Highly wear resistant hot working steel M2 (1.3343) 54+2 HRC

**IT** > Inserto lavorabile, che fa risparmiare molto spazio, per punto d'iniezione sotto la linea di divisione dello stampo  
> Acciaio per lavorazioni a caldo particolarmente resistente all'usura M2 (1.3343) 54+2 HRC

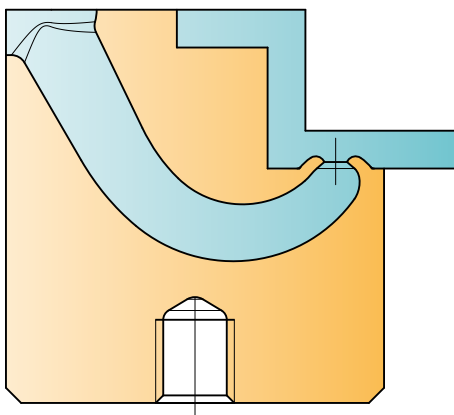

TGLL



	TGLL-1	TGLL-2	TGLL-3
max. Konturtiefe / max. contour depth / max. profondità di contornatura	8,5	10,5	12,5
⊘ Anschnitt / gate point / punto d'iniezione	0,6 - 1,2	0,8 - 1,8	0,5x4,5 - 1,5x5,5
⊘ Kanal / runner / canale	4	6	8
<b>max. Schussgewichte (g) · max. shotweight (g) · pesi d'iniezione max. (g)</b>			
<b>NV</b>	35	120	1000
<b>MV</b>	25	75	500
<b>HV</b>	15	50	300

NV = niedrige Viskosität / low viscosity / bassa viscosità  
MV = mittlere Viskosität / medium viscosity / media viscosità  
HV = hohe Viskosität / high viscosity / elevata viscosità

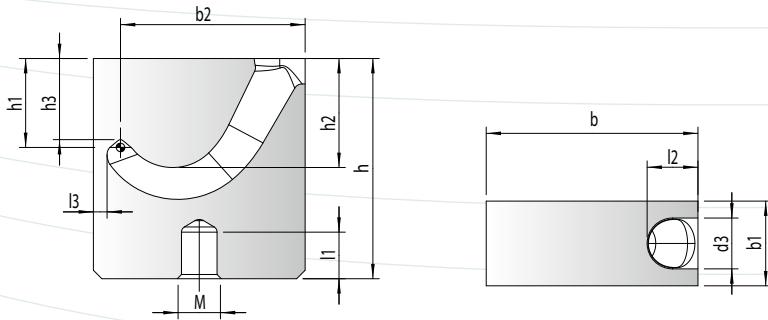

Typ LL	b	b1	b2	d3	h	h1	h2	h3	l1	l2	l3	M	HRC
TGLL-1	18	8	15,7	4	22	8,5	9,9	7,8	5,5	4,5	1,2	5	54+2
TGLL-2	25	10	21,8	6	26	10,5	12,9	9,6	5,5	6	1,6	5	
TGLL-3	30	12	26	8	30	12,5	14,8	11,6	6,5	7	2,2	6	

### Beispiel für 2-fach Ausführung

Example for 2 cavities  
Esempio di stampo a 2 cavità

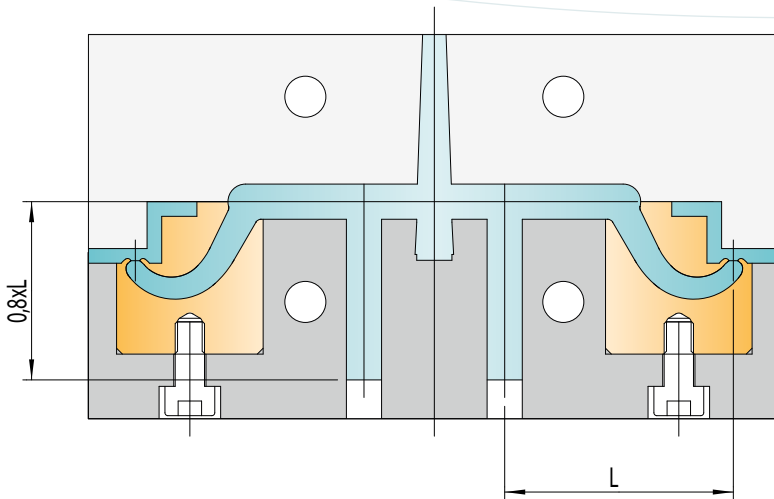

### Beispiel für 1-fach Ausführung

Example for single cavity  
Esempio di stampo a 1 cavità

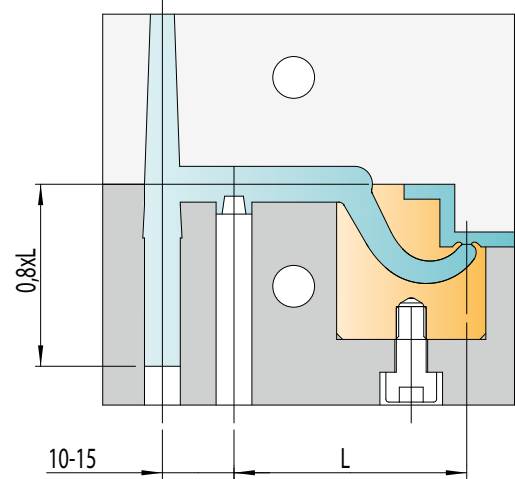

### Beispiel Geometrie für Hilfsauswerfer

Example for supplementary ejector  
Esempio con estrattore ausiliare

Diagramm für Abstandsmaß L · Table for distance L · Diagramma per la distanza L				
Materialart · Material type · Tipo di materiale				
	TPE, TPU, etc.	PE, PP, PET, etc.	PC, ABS, PA, POM, HI-PC, etc.	PA+GF, PC, SAN, PMMA, etc.
TG-1 (HL,ML,LL)	21-27	27-34	34-40	X
TG-2 (HL,ML,LL)	28-34	33-40	39-45	X
TG-3 (HL,ML,LL)	33-40	40-49	46-55	X

**X = Für spröde und verstärkte Kunststoffe bedingt geeignet** · Restrictedly suitable for rigid and reinforced plastics · Adatto esclusivamente per plastiche rigide e rinforzate

➔ **Kalottengestaltung > siehe ergänzende Tipps (Seite 36)** · Vestige design > see additional tips (page 36) · Design della calotta à vedi dati aggiuntivi (pagina 36)

# TGML

konturierbar  
contourable  
contornabile

Für spröde und verstärkte Kunststoffe bedingt geeignet · Restrictedly suitable for rigid and reinforced plastics ·  
Adatto esclusivamente per plastiche rigide e rinforzate



- DE** > platzsparender, konturierbarer Angusseinsatz für Anspritzung oberhalb der Formtrennung  
> hoch verschleißfester Warmarbeitsstahl M2 (1.3343) 54+2 HRC
- EN** > Space-saving, contourable Tunnel Gate insert for gating above the parting line  
> Highly wear resistant hot working steel M2 (1.3343) 54+2 HRC
- IT** > Inserto lavorabile, che fa risparmiare molto spazio, per punto d'iniezione sotto la linea di divisione dello stampo  
> Acciaio per lavorazioni a caldo particolarmente resistente all'usura M2 (1.3343) 54+2 HRC

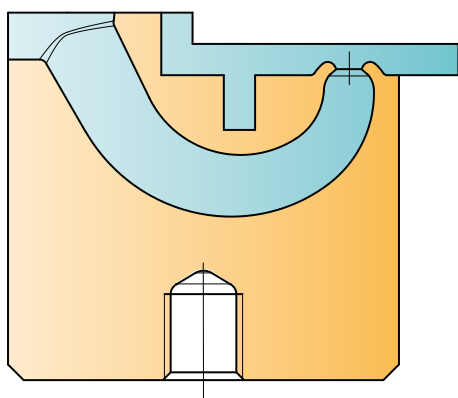

	TGML-1	TGML-2	TGML-3
max. Konturtiefe / max. contour depth / max. profondità di contornatura	5,5	6,5	7,5
∅ Anschnitt / gate point / punto d'iniezione	0,6 - 1,2	0,8 - 1,8	0,5x4,5 - 1,5x5,5
∅ Kanal / runner / canale	4	6	8
<b>max. Schussgewichte (g) · max. shotweight (g) · pesi d'iniezione max. (g)</b>			
<b>NV</b>	35	120	1000
<b>MV</b>	25	75	500
<b>HV</b>	15	50	300

NV = niedrige Viskosität / low viscosity / bassa viscosità  
MV = mittlere Viskosität / medium viscosity / media viscosità  
HV = hohe Viskosität / high viscosity / elevata viscosità

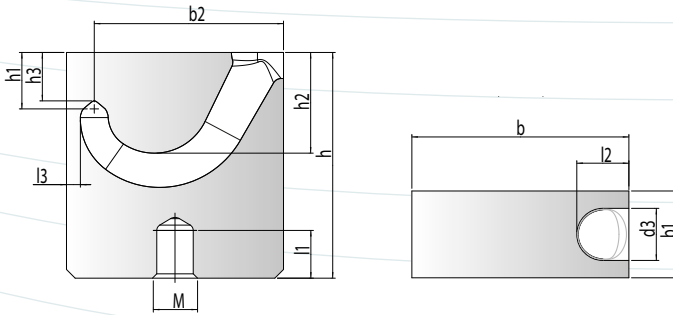

Typ ML	b	b1	b2	d3	h	h1	h2	h3	l1	l2	l3	M	HRC
TGML-1	18	8	15,7	4	22	5,5	9,5	4,86	5,5	4,5	1,2	5	54+2
TGML-2	25	10	21,8	6	26	6,5	11,6	5,6	5,5	6	1,6	5	
TGML-3	30	12	26	8	30	7,5	14,5	6,6	6,5	7	2,0	6	

### Beispiel für 2-fach Ausführung

Example for 2 cavities  
Esempio di stampo a 2 cavità

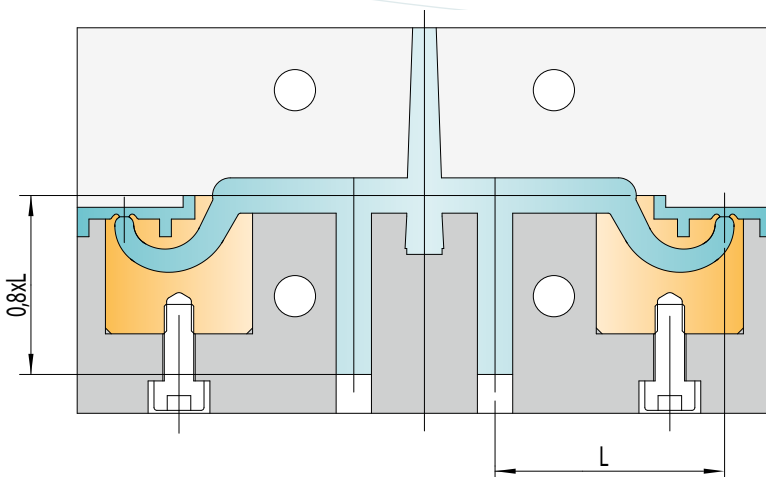

### Beispiel für 1-fach Ausführung

Example for single cavity  
Esempio di stampo a 1 cavità

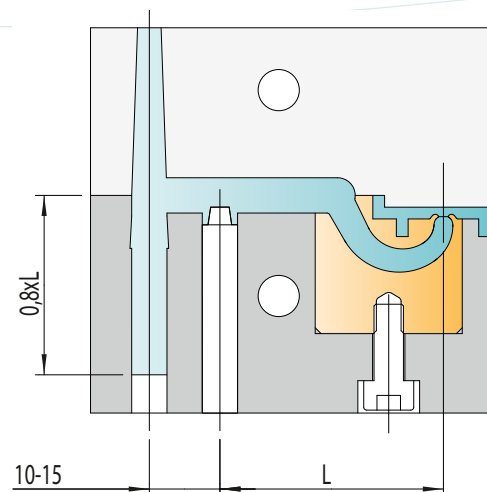

### Beispiel Geometrie für Hilfsauswerfer

Example for supplementary ejector  
Esempio con estrattore ausiliare

### Diagramm für Abstandsmaß L · Table for distance L · Diagramma per la distanza L

	Materialart · Material type · Tipo di materiale			
	TPE, TPU, etc.	PE, PP, PET, etc.	PC, ABS, PA, POM, HI-PC, etc.	PA+GF, PC, SAN, PMMA, etc.
TG-1 (HL,ML,LL)	21-27	27-34	34-40	X
TG-2 (HL,ML,LL)	28-34	33-40	39-45	X
TG-3 (HL,ML,LL)	33-40	40-49	46-55	X

**X = Für spröde und verstärkte Kunststoffe bedingt geeignet** · Restrictedly suitable for rigid and reinforced plastics · Adatto esclusivamente per plastiche rigide e rinforzate

➔ **Kalottengestaltung > siehe ergänzende Tipps (Seite 36)** · Vestige design > see additional tips (page 36) · Design della calotta à vedi dati aggiuntivi (pagina 36)

# TGHL

konturierbar  
contourable  
contornabile

**Für spröde und verstärkte Kunststoffe nicht geeignet** · Not suitable for rigid and reinforced plastics ·  
Non adatto per plastiche rigide e rinforzate.



**DE** > platzsparender, konturierbarer Angusseinsatz für Anspritzung oberhalb der Formtrennung  
> hoch verschleißfester Warmarbeitsstahl M2 (1.3343) 54+2 HRC

**EN** > Space-saving, contourable Tunnel Gate insert for gating above the parting line  
> Highly wear resistant hot working steel M2 (1.3343) 54+2 HRC

**IT** > Inserto lavorabile, che fa risparmiare molto spazio, per punto d'iniezione sotto la linea di divisione dello stampo  
> Acciaio per lavorazioni a caldo particolarmente resistente all'usura M2 (1.3343) 54+2 HRC

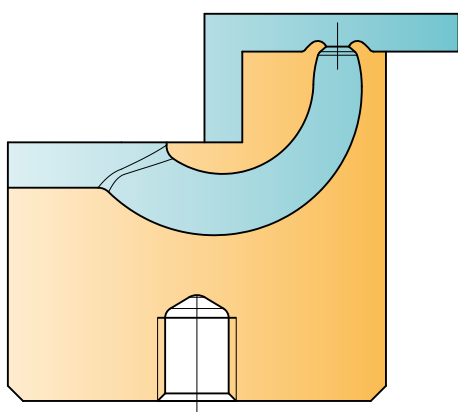

	TGHL-1	TGHL-2	TGHL-3
max. Konturtiefe / max. contour depth / max. profondità di contornatura	2	3	3
∅ Anschnitt / gate point / punto d'iniezione	0,6 - 1,2	0,8 - 1,8	0,5x4,5 - 1,5x5,5
∅ Kanal / runner / canale	4	6	8
<b>max. Schussgewichte (g) · max. shotweight (g) · pesi d'iniezione max. (g)</b>			
<b>NV</b>	35	120	1000
<b>MV</b>	25	75	500
<b>HV</b>	15	50	300

NV = niedrige Viskosität / low viscosity / bassa viscosità  
MV = mittlere Viskosität / medium viscosity / media viscosità  
HV = hohe Viskosität / high viscosity / elevata viscosità

Kalotte nach 3D Datensatz  
Vestige by 3D file  
Calotta 3D

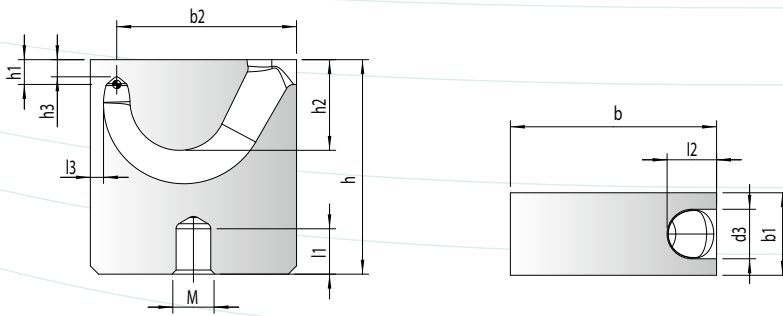

Typ HL	b	b1	b2	d3	h	h1	h2	h3	l1	l2	l3	M	HRC
TGHL-1	18	8	15,7	4	22	2	7,6	1,3	5,5	4,5	1,2	5	54+2
TGHL-2	25	10	21,8	6	26	3	11	2,1	5,5	6	1,6	5	
TGHL-3	30	12	26	8	30	3	12,2	2,1	6,5	7	2,0	6	

**Beispiel für 2-fach Ausführung**

Example for 2 cavities  
Esempio di stampo a 2 cavità

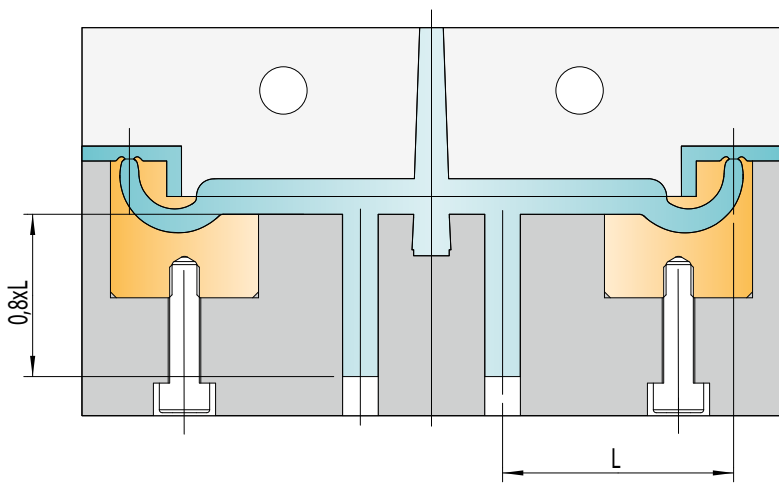

**Beispiel für 1-fach Ausführung**

Example for single cavity  
Esempio di stampo a 1 cavità

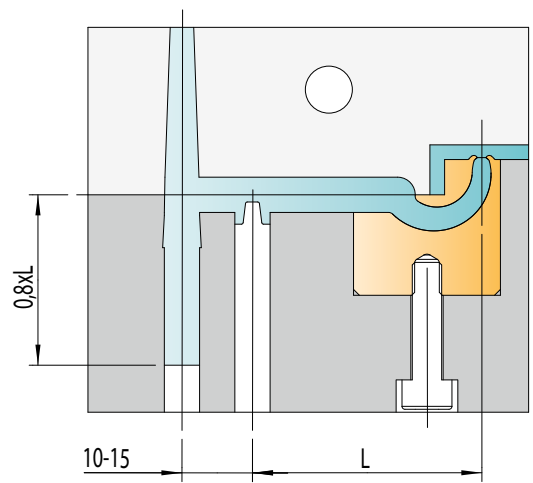

TGHL

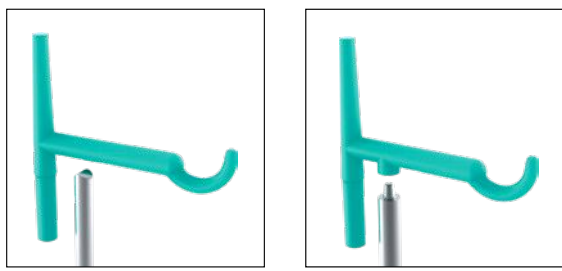

**Beispiel Geometrie für Hilfsauswerfer**

Example for supplementary ejector  
Esempio con estraattore ausiliare

**Diagramm für Abstandsmaß L · Table for distance L · Diagramma per la distanza L**

	Materialart · Material type · Tipo di materiale			
	TPE, TPU, etc.	PE, PP, PET, etc.	PC, ABS, PA, POM, HI-PC, etc.	PA+GF, PC, SAN, PMMA, etc.
TG-1(HL,ML,LL)	21-27	27-34	34-40	X
TG-2(HL,ML,LL)	28-34	33-40	39-45	X
TG-3(HL,ML,LL)	33-40	40-49	46-55	X

**X = Für spröde und glasfaserverstärkte Materialien nicht geeignet** · Not suitable for rigid and reinforced plastics · Non adatto per plastiche rigide e rinforzate

# Einbaubeispiele TGLL / TGML / TGHL

Examples of installation · Esempi di montaggio

## TGLL tiefer Kontursprung / TGLL low contour step / TGLL profilo inferiore



## TGML mit umlaufender Rippe / TGML with peripheral rib / TGML con nervatura circostante



## TGHL hoher Kontursprung / TGHL high contour step / TGHL profilo superiore

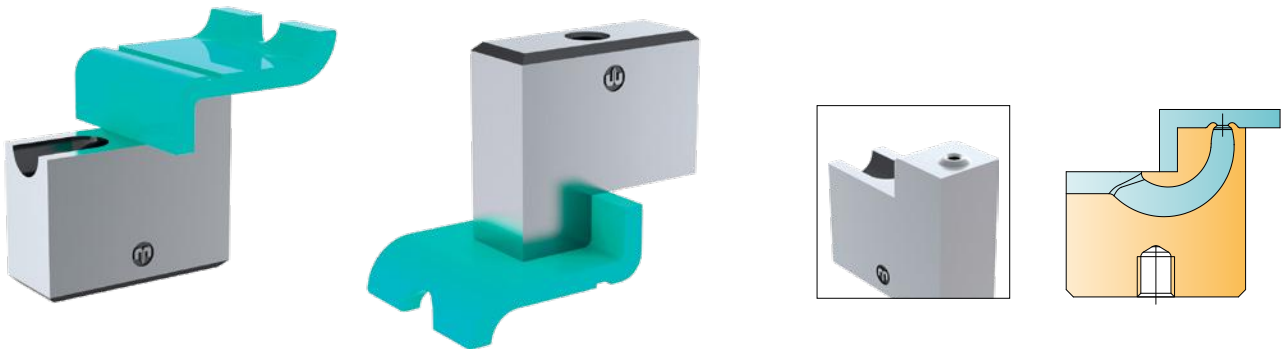

## TGHL mit umlaufender Rippe / TGHL with peripheral rib / TGHL con nervatura circostante





# SGC

seitliche Anspritzung  
side gating  
iniezione laterale

Geeignet für alle Kunststoffe · Suitable for all plastics · Adatto per ogni tipo di plastica

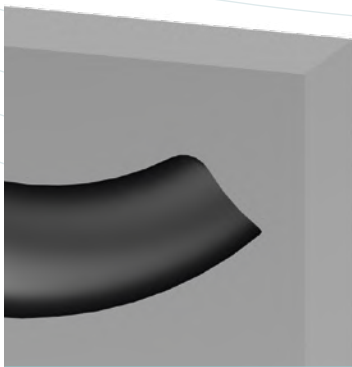

- DE** > gebogener Kanal ermöglicht die Anspritzung in Bereichen, die tief im Bauteil liegen  
> integrierter Stauboden reduziert Druckverlust und Scherung  
> hoch verschleißfester Warmarbeitsstahl M2 (1.3343) – 54+2 HRC
- EN** > curved tunnel permits gating deep inside the part  
> integrated dead-end recess reduces loss of pressure and shear stress.  
> highly wear-resistant hot working steel M2 (1.3343) – 54+2 HRC
- IT** > il canale curvato consente l'iniezione in zone profonde del componente  
> il fondo di ritenzione integrato riduce la perdita di pressione e l'attrito  
> acciaio per lavorazioni a caldo particolarmente resistente all'usura M2 (1.3343) – 54+2 HRC

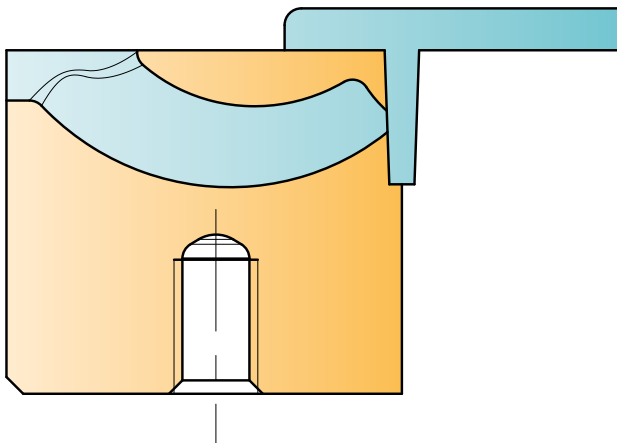

	SGC-XS	SGC-S	SGC-1	SGC-2	SGC-3
∅ Anschnitt / gate point / punto d'iniezione	0,4 - 0,8	0,4 - 1,0	0,6 - 1,4	0,8 - 2,1	~ ∅ 1,1 - 3,3
∅ Kanal / runner / canale	2.5	2.5	4	6	8

	max. Schussgewichte (g) · max. shotweight (g) · pesi d'iniezione max. (g)				
<b>NV</b>	12	20	35	250	1000
<b>MV</b>	7	12	25	120	500
<b>HV</b>	5	8	15	90	300

NV = niedrige Viskosität / low viscosity / bassa viscosità  
MV = mittlere Viskosität / medium viscosity / media viscosità  
HV = hohe Viskosität / high viscosity / elevata viscosità

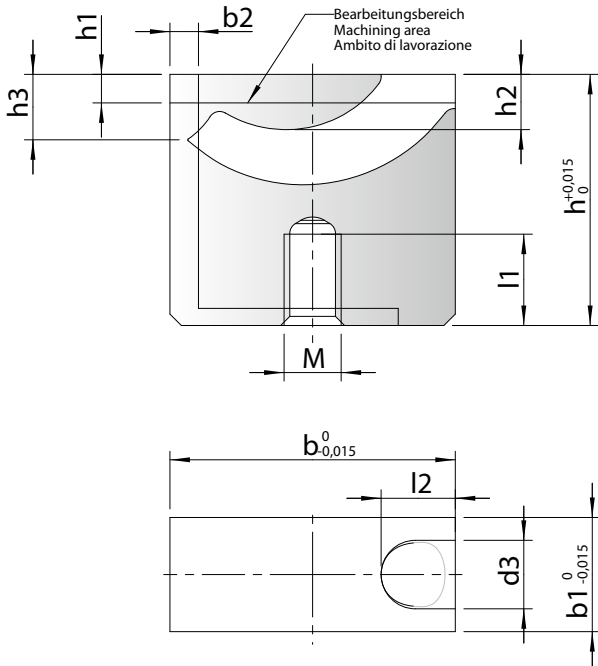

## SGC-XS / SGC-S

**Befestigungsmöglichkeiten**  
Mounting possibilities  
Possibilità di fissaggio

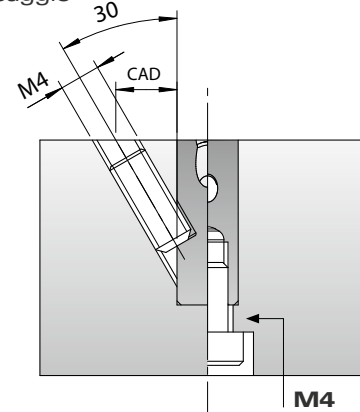

Typ	b	b1	b2 max.	d3	h	h1 max.	h2	h3	l1	l2	M
SGC-XS	10	5	1.1	2.5	12	0.6	1.9	2.0	5	3.2	4
SGC-S	15	6	2.0	2.5	18	2	3.5	4.0	8	4	4
SGC-1	18	8	1.8	4	22	2	3.5	4.1	9	5.2	5
SGC-2	25	10	2.5	6	22	2.5	4.8	5.7	8	6.5	5
SGC-3	30	12	2.8	8	27	4.5	7.5	8.4	9	7	6

➔ Beispiel Bestellbezeichnung · Example of order specification · Esempio codice di ordinazione: **SGC-XS**

### SGC-XS

A [mm <sup>2</sup> ]	~ Ø [mm]	b2 [mm]
0.13	0.4	0.9
0.3	0.6	1.0
0.53	0.8	1.1

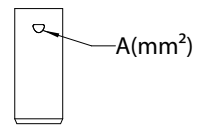
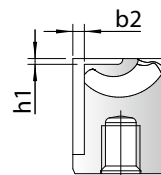

### SGC-S

A [mm <sup>2</sup> ]	~ Ø [mm]	b2 [mm]
0.15	0.4	1.7
0.33	0.6	1.8
0.55	0.8	1.9
0.79	1.0	2.0

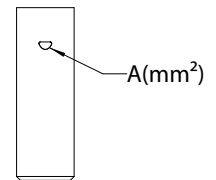
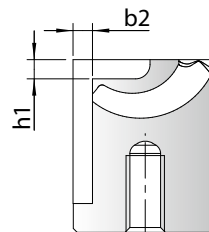

### SGC-1

A [mm <sup>2</sup> ]	~ Ø [mm]	b2 [mm]
0.28	0.6	1.4
0.53	0.8	1.5
0.82	1	1.6
1.15	1.2	1.7
1.52	1.4	1.8

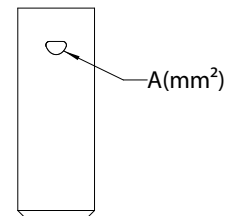
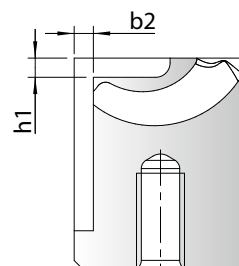

### SGC-2

A [mm <sup>2</sup> ]	~ Ø [mm]	b2 [mm]
0.28	0.6	1.7
0.54	0.8	1.8
0.84	1	1.9
1.2	1.2	2
1.57	1.4	2.1
2	1.6	2.2
2.43	1.75	2.3
2.9	1.9	2.4
3,4	2,1	2,5

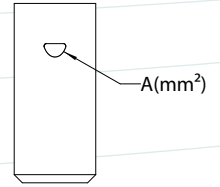
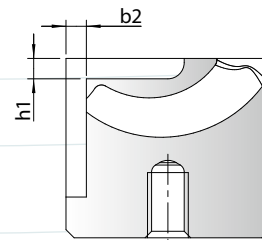

### SGC-3

A [mm <sup>2</sup> ]	~ Ø [mm]	b2 [mm]
1	1.1	2
1.75	1.5	2.1
2.56	1.8	2.2
3.43	2.1	2.3
4.35	2.35	2.4
5.32	2.6	2.5
6.33	2.85	2.6
7.38	3	2.7
8.48	3.3	2.8

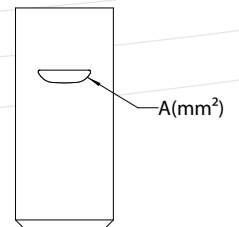
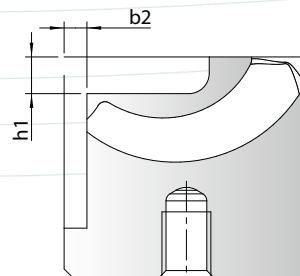

#### Standardeinbau für flache und mittlere Konturtiefen

Standard installation for shallow and medium contour depths

Montaggio standard per medie ed elevate profondità di contornatura

#### Sondereinbau für große Konturtiefen

Special installation for deep contours

Montaggio speciale per grandi profondità di contornatura

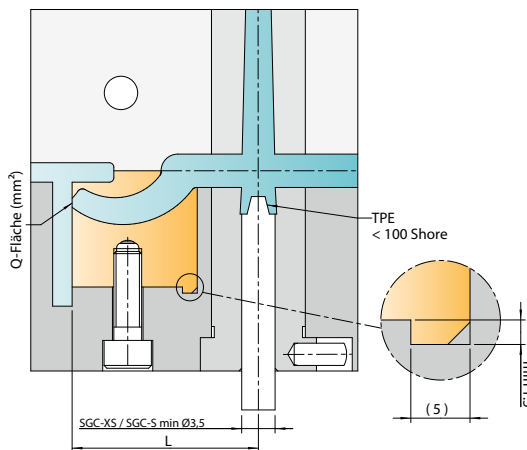
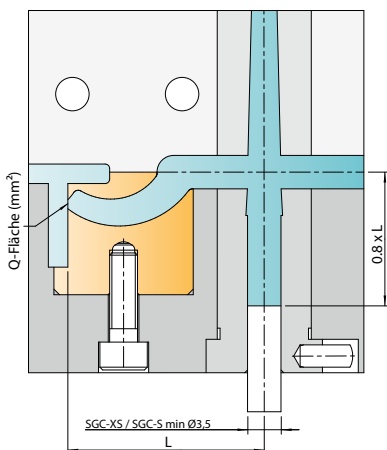

#### DE Thermoplastische Elastomere (TPE)

- > Kleine Shorehärte = geringeres Abstandsmaß L
- > Zentrierzapfen verwenden
- > Shorehärte max. 100 Shore A

#### EN Thermoplastic elastomers (TPE)

- > Low Shore hardness = shorter distance L
- > Use centring pin
- > Max. hardness 100 Shore A

#### IT Elastomeri termoplastici (TPE)

- > Bassa durezza Shore = distanza L più ridotta
- > Utilizzare un perno di guida
- > Durezza: max. 100 Shore A

SGC

### Diagramm für Abstandsmaß L · Table for distance L · Diagramma per la distanza L

#### Materialart · Material type · Tipo di materiale

	TPE, TPU etc.	PE, PP, PET etc.	PC, ABS, PA, POM, HI-PC, etc.	PA+GF, PC, SAN, PMMA etc.
SGC-XS	12-16	13-20	16-23	22-29
SGC--S	16-21	18-25	21-28	27-34
SGC--1	21-26	26-34	31-39	36-45
SGC--2	28-33	31-39	36-44	41-50
SGC--3	33-38	38-48	43-53	48-58

# Einbaubeispiele

Examples of installation · Esempi di montaggio

## Seitliche Anspritzung – Standard Einbau

Side gating – standard installation

Iniezione laterale – montaggio standard

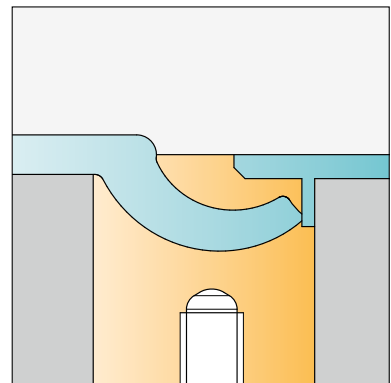
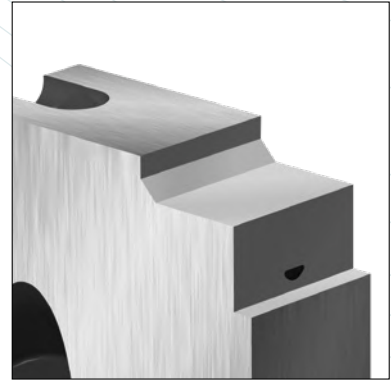
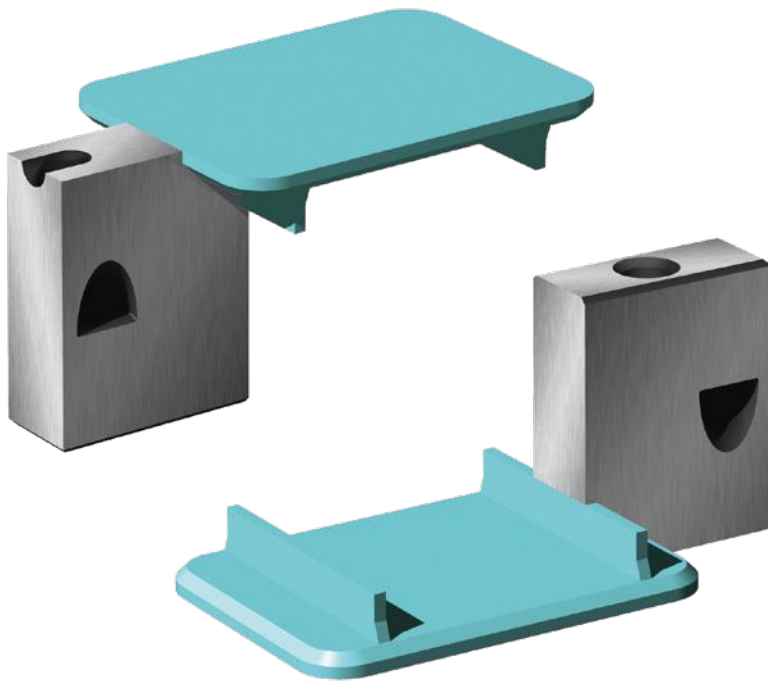

## Seitliche Anspritzung – angepasst an Teil

Side gating – adapted to part

Iniezione laterale – adattata al pezzo

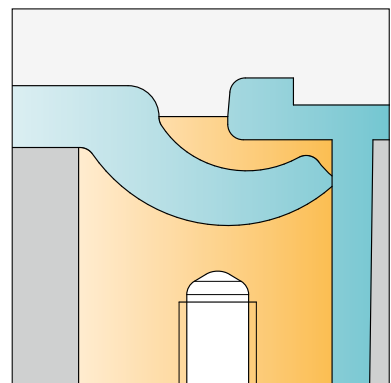
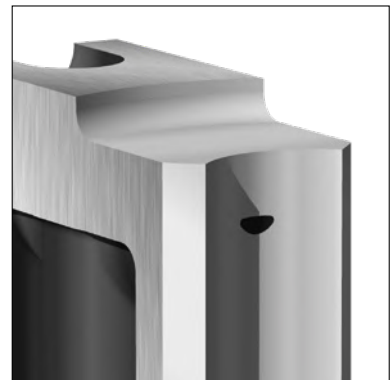
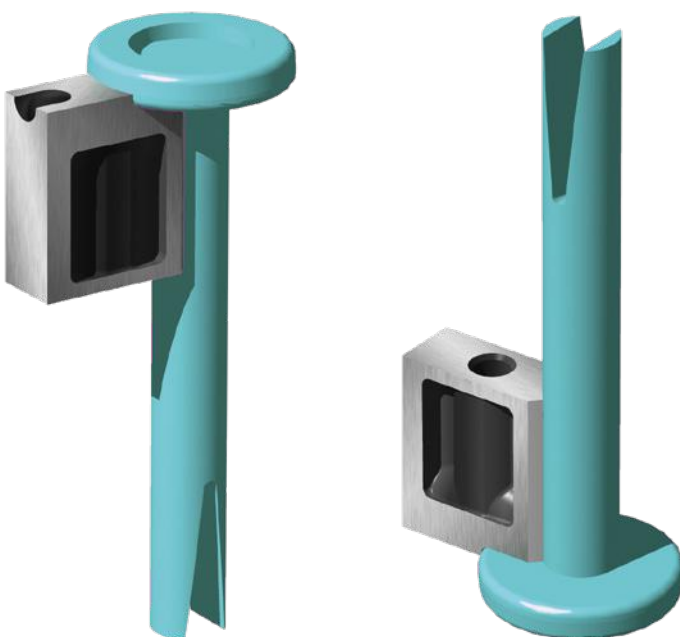

# TPS

seitliche Anspritzung  
side gating  
iniezione laterale

Geeignet für alle Kunststoffe · Suitable for all plastics · Adatto per ogni tipo di plastica

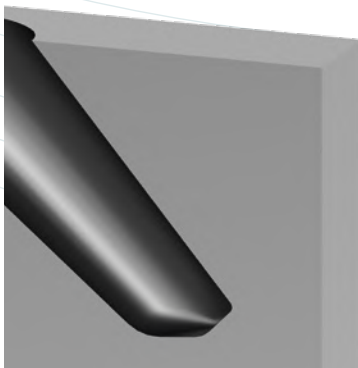

- DE** > **standardisierter Spitztunnel zur seitlichen Anspritzung**
- > **integrierter Stauboden reduziert Druckverlust und Scherung**
- > **hoch verschleißfester Warmarbeitsstahl M2 (1.3343) – 54+2 HRC**
- EN** > straight standard sub-gate for side-gating
- > integrated dead-end recess reduces loss of pressure and shear stress.
- > highly wear-resistant hot working steel M2 (1.3343) – 54+2 HRC
- IT** > tunnel di iniezione standard per iniezione laterale
- > il fondo di ritenzione integrato riduce la perdita di pressione e l'attrito
- > acciaio per lavorazioni a caldo particolarmente resistente all'usura M2 (1.3343) – 54+2 HRC

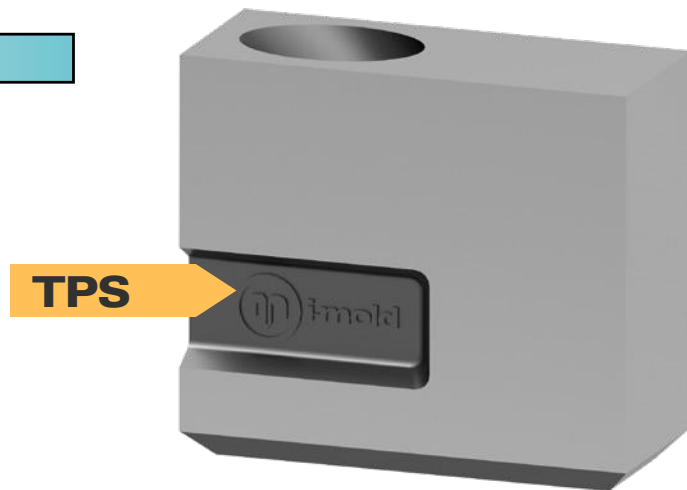
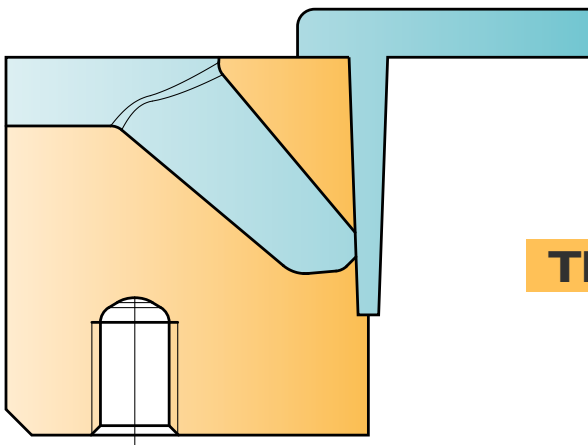

	TPS-S	TPS-1	TPS-2	TPS-3
 Anchnitt / gate point / punto d'iniezione	0,4 - 0,8	0,8 - 1,8	0,8 - 2,8	1,1 - 4,5
<b>max. Schussgewichte (g) · max. shotweight (g) · pesi d'iniezione max. (g)</b>				
<b>NV</b>	30	120	600	1800
<b>MV</b>	20	75	350	1000
<b>HV</b>	12	50	175	600

NV = niedrige Viskosität / low viscosity / bassa viscosità  
MV = mittlere Viskosität / medium viscosity / media viscosità  
HV = hohe Viskosität / high viscosity / elevata viscosità

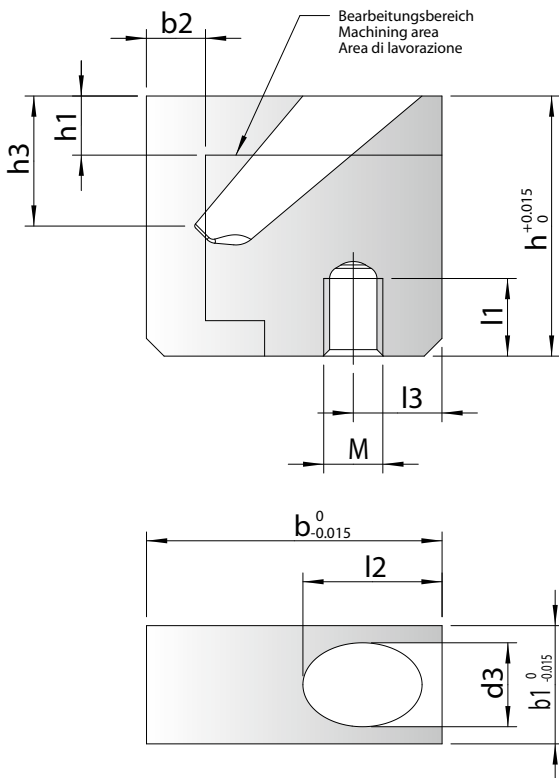

## TPS

### Befestigungsmöglichkeiten Mounting possibilities Possibilità di fissaggio

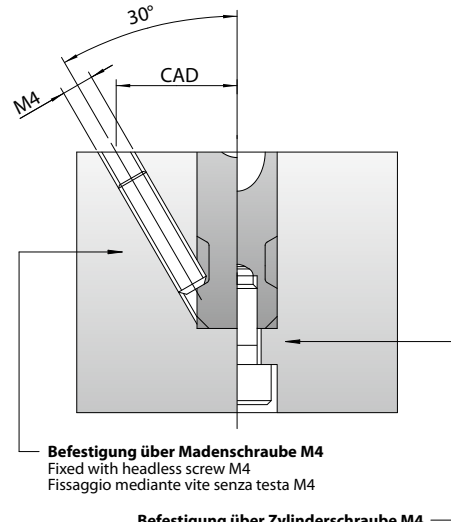

**Befestigung über Madenschraube M4**  
Fixed with headless screw M4  
Fissaggio mediante vite senza testa M4

**Befestigung über Zylinderschraube M4**  
Fixed with hexagon screw M4  
Fissaggio mediante vite a testa cilindrica M4

Typ	b	b1	b2 max.	d3	h	h1 max.	h3	l1	l2	l3	M
TPS-S	15	6	2.4	4	18	4	~7	6	7.1	5.5	4
TPS-1	18	8	2.6	6	22	5	~9	6	8.4	6	4
TPS-2	25	10	5	8	22	6	~11	6	11.8	7.5	5
TPS-3	30	12	6.5	10	27	7	~13	6	14.1	8	5

➔ Beispiel Bestellbezeichnung · Example of order specification · Esempio codice di ordinazione: **TPS-1**

### TPS-S

A [mm <sup>2</sup> ]	~ Ø [mm]	b2 [mm]
0.12	0.4	2.1
0.40	0.7	2.2
0.75	1.0	2.3
1.13	1.2	2.4

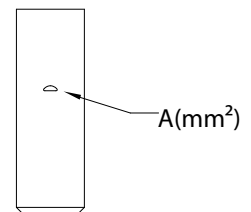
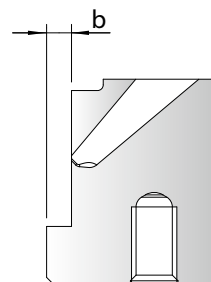

### TPS-1

A [mm <sup>2</sup> ]	~ Ø [mm]	b2 [mm]
0.49	0.8	2.2
0.92	1.1	2.3
1.42	1.4	2.4
1.97	1.6	2.5
2.56	1.8	2.6

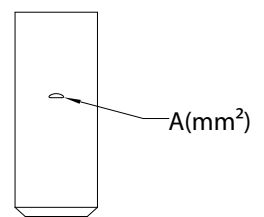
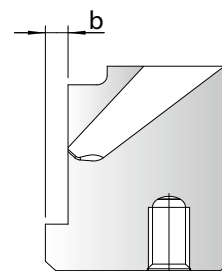

### TPS-2

A [mm <sup>2</sup> ]	~ Ø [mm]	b2 [mm]
0.54	0.8	4.2
1.05	1.2	4.3
1.64	1.5	4.4
2.3	1.7	4.5
3.0	1.9	4.6
3.76	2.2	4.7
4.55	2.4	4.8
5.37	2.6	4.9
6.23	2.8	5.0

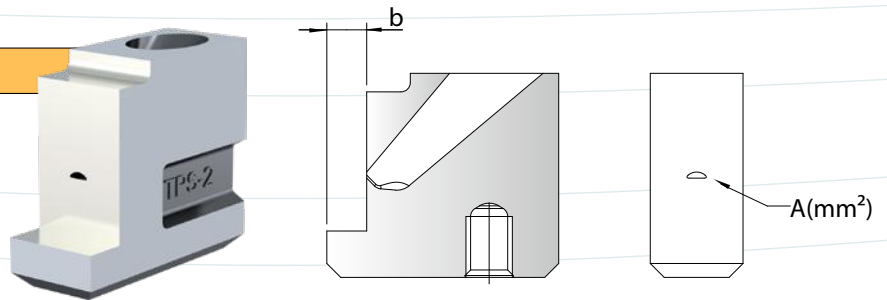

### TPS-3

A [mm <sup>2</sup> ]	~ Ø [mm]	b2 [mm]
1.0	1.1	5.2
1.81	1.5	5.3
2.7	1.9	5.4
3.67	2.2	5.5
4.7	2.4	5.6
5.78	2.7	5.7
6.92	3.0	5.8
8.09	3.2	5.9
9.3	3.4	6.0
max. 15.8	4.5	6.5

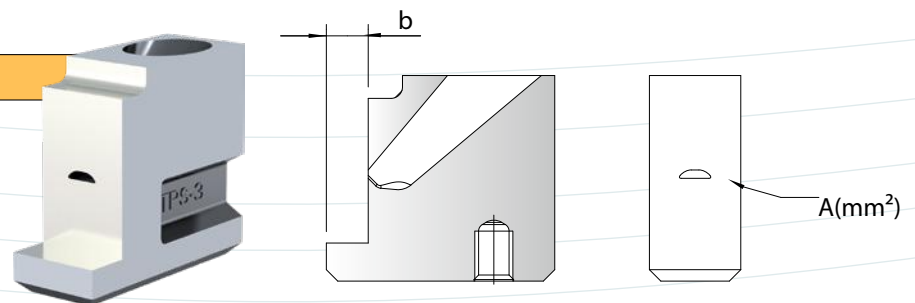

#### Standardeinbau für flache und mittlere Konturtiefen

Standard installation for shallow and medium contour depths  
 montaggio standard per pareti di bassa e media profondità

#### Sondereinbau für große Konturtiefen

Special installation for deep contours  
 montaggio standard per pareti di alta profondità

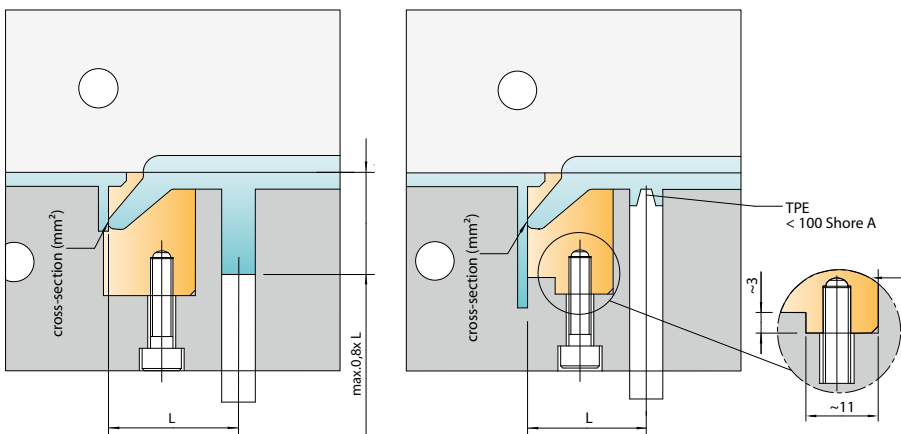

#### DE Thermoplastische Elastomere (TPE)

- > Niedrige Shorehärte = geringeres Abstandsmaß L
- > Zentrierzapfen verwenden
- > Shorehärte max. 100 Shore A

#### EN Thermoplastic elastomers (TPE)

- > Low Shore hardness = shorter distance L
- > Use centring pin
- > Max. hardness 100 Shore A

#### IT Elastomeri termoplastici (TPE)

- > Bassa durezza Shore = distanza L più ridotta
- > Utilizzare un perno di guida
- > Durezza: max. 100 Shore A

### Diagramm für Abstandsmaß L · Table for distance L · Diagramma per la distanza L

Materialart · Material type · Tipo di materiale		
	flexible Materialien flexible materials · materiali flessibili	steife Materialien rigid materials · materiali rigidi
TPS-S	~ 18	~ 23
TPS-1	~ 22	~ 30
TPS-2	~ 28	~ 38
TPS-3	~ 33	~ 47

# Einbaubeispiele

Examples of installation · Esempi di montaggio

## Seitliche Anspritzung - Standard Einbau

Side gating - standard installation

Iniezione laterale - montaggio standard

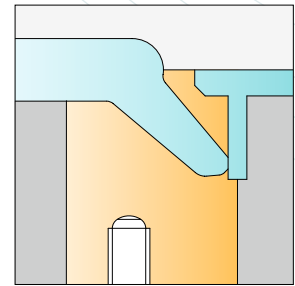
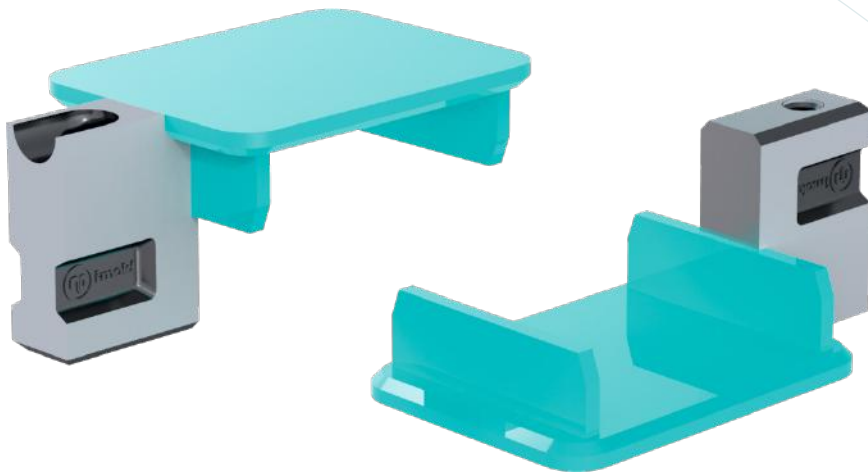

## Seitliche Anspritzung - für flache Konturtiefen

Side gating - for flat contours

Iniezione per pareti laterali poco profonde

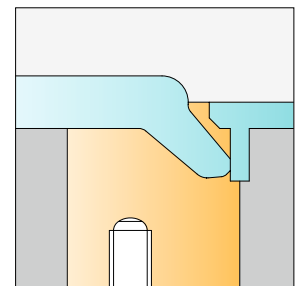
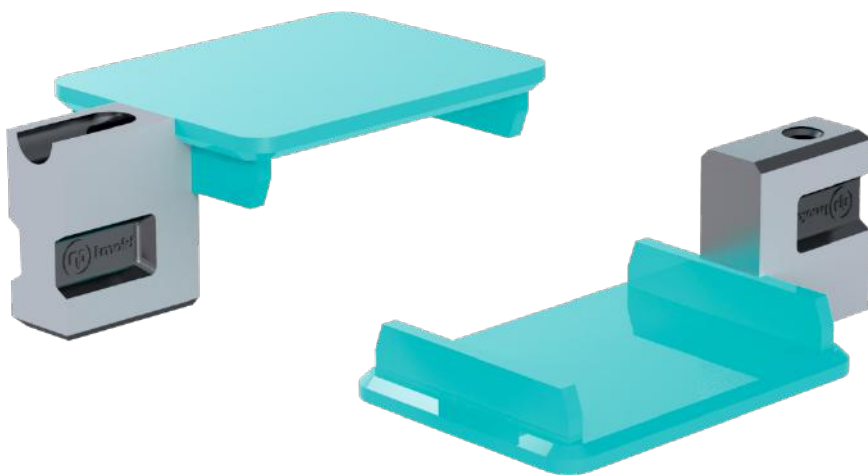

## Seitliche Anspritzung - für große Konturtiefen

Side gating - for deep contours

iniezione per pareti laterali molto profonde

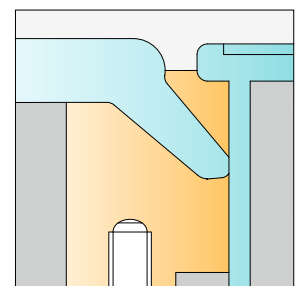



# Haltebuchse

Retaining bush  
Boccola di arresto

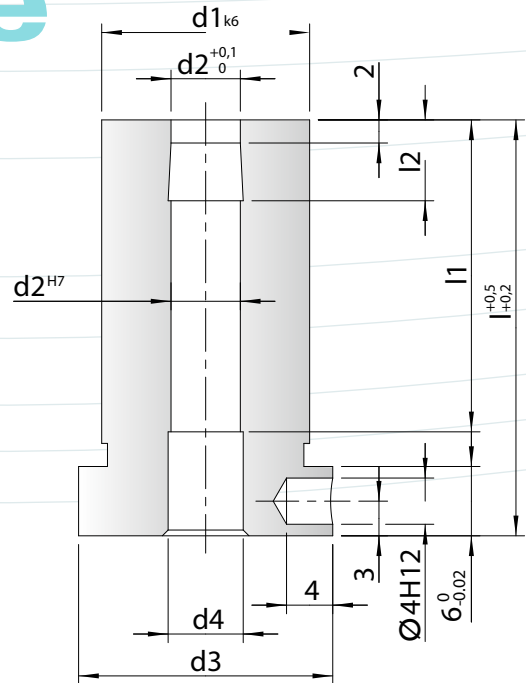

l	l1	l2	d1	d2	d3	d4	Order No:
36	36						RB4-36
46	46	7	12	4	16	4.5	RB4-46
56	46						RB4-56
36	36						RB6-36
46	46	7	18	6	22	6.5	RB6-46
56	56						RB6-56
66	56						RB6-66
46	46						RB8-46
56	56	9.5	24	8	28	8.5	RB8-56
66	66						RB8-66

Material: 2826 ~58 HRC

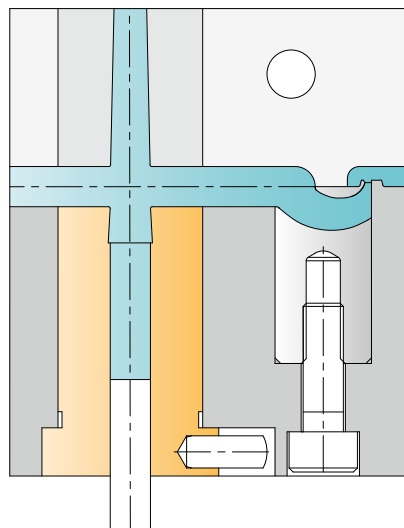

# Ergänzende Tipps

Supplementary tips · Consigli supplementari

## Stauboden · Dead-end recess · Fondo di ritenzione

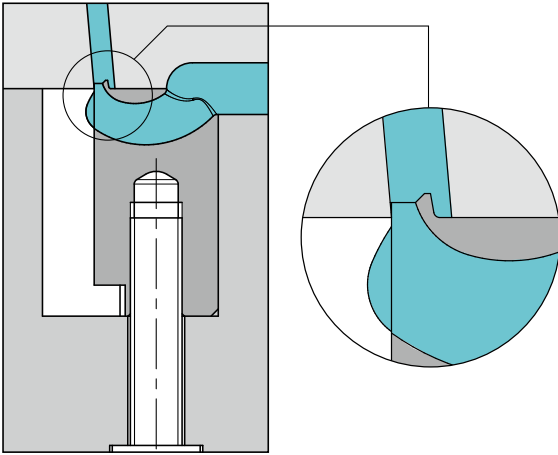

**DE** Zur Anspritzung von Gehäuseteilen empfehlen wir einen Stauboden in ein Hilfsplättchen oder direkt in den Formeinsatz einzubringen. Der Stauboden verringert die Schergeschwindigkeit im Anschnittbereich, verbessert den Quellfluss, reduziert den Druckverlust und wirkt der Freistrahlabildung entgegen.

**EN** For the gating of housing parts we recommend incorporating a dead-end recess in an auxiliary insert or directly in the mould insert. This feature optimizes the shear velocity in the gate area, gives a superior frontal flow, reduces the pressure loss and helps prevent jetting.

**IT** Per l'iniezione di parti di contenitori consigliamo di inserire un fondo di ritenzione in una piastrina ausiliare o direttamente nell'inserto dello stampo. Il fondo di ritenzione riduce la velocità di taglio nella zona d'iniezione, migliora il flusso laminare, riduce la perdita di pressione e previene la formazione di un getto libero.

## Stauboden-Elektrode · Spark-erosion machining of recesses · Elettrodo del fondo di ritenzione

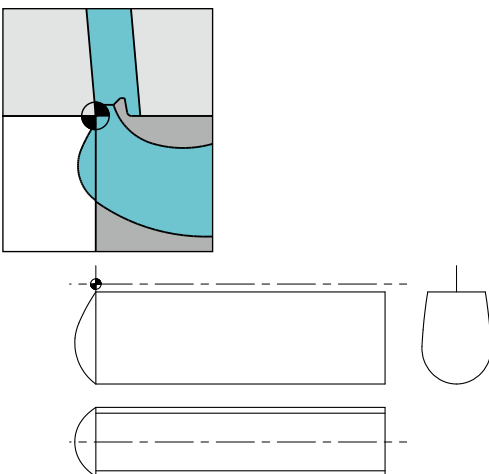

**DE** Beim Fertigen des Staubodens sollte darauf geachtet werden, dass kein Hinterschnitt zum Angusskanal entsteht. Die 3D-Daten für die jeweilige Größe der Standard-Angussseinsätze finden Sie unter [www.i-mold.de](http://www.i-mold.de) im Downloadbereich.

**EN** When machining the recess, take care to avoid undercutting the runner. For 3D data relating to standard insert sizes please refer to [www.i-mold.com](http://www.i-mold.com) (download section).

**IT** Per la realizzazione del fondo di ritenzione si deve fare attenzione ad evitare un sotto squadra verso il canale di alimentazione. I dati 3D per le rispettive dimensioni degli inserti d'iniezione standard possono essere scaricati presso [www.i-mold.com](http://www.i-mold.com) nell'area di download.

## Hilfsplättchen · Auxiliary insert · Piastrine ausiliari

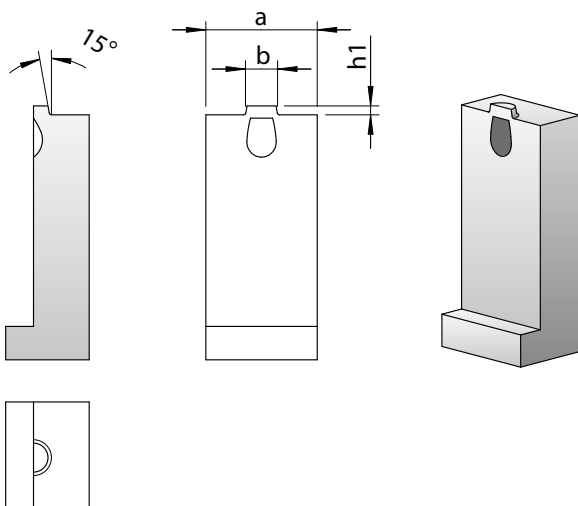

**DE** Gegenkalotte und/oder Stauboden können auch direkt in den Formeinsatz eingebracht werden. Das Hilfsplättchen sollte aus einem hoch verschleißfesten Stahl hergestellt werden.

Maße a, b und h1 sind vom jeweiligen Standard-Angussseinsatz abhängig.

**EN** The companion vestige and/or dead-end recess can also be incorporated directly in the mould insert. The auxiliary insert should be made of a highly wear-resistant steel.

The dimensions a, b and h1 depend on the actual standard gate insert used.

**IT** La controcalotta e/o il fondo di ritenzione possono anche essere inseriti direttamente nell'inserto dello stampo. Per la piastrina ausiliare si dovrebbe utilizzare un acciaio particolarmente resistente all'usura.

Le misure a, b e h1 dipendono dal rispettivo inserto d'iniezione standard.

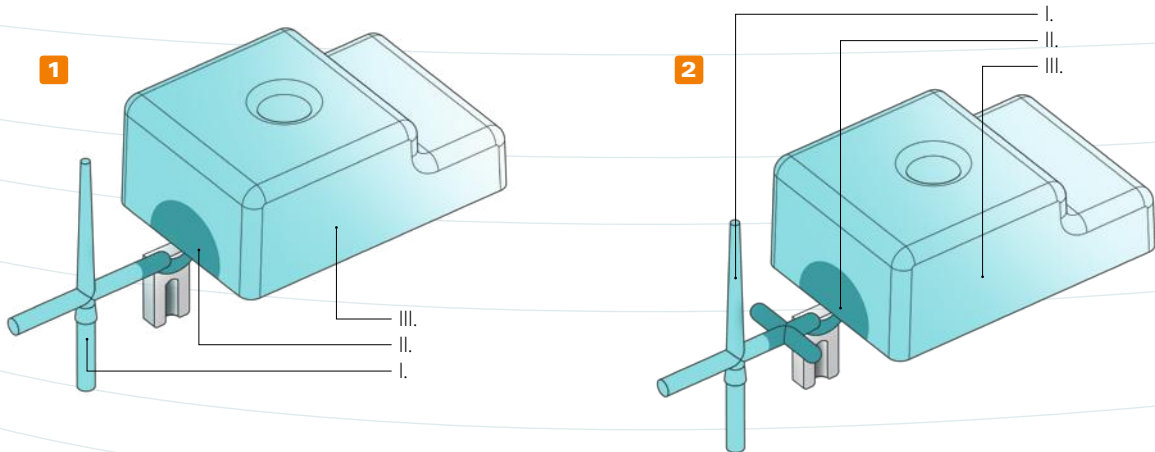

**DE** Um die Gefahr von Freistrahlbildung und einem matten Hof im Anschnittbereich zu mindern, empfehlen wir ein gestuftes Einspritzprofil zu verwenden.

**EN** To avoid the risk of jetting and the formation of matt halo effects in the gate area, we recommend the use of a graduated injection profile.

**IT** Consigliamo l'impiego di un profilo d'iniezione graduato per ridurre il rischio di formazione di un getto libero e di un alone opaco nella zona d'iniezione.

**DE**

**1 Maschinell gestuftes Einspritzprofil**

- I. Hohe Einspritzgeschwindigkeit zum Füllen des Kaltkanalverteilers.
- II. Niedrige Einspritzgeschwindigkeit, um optimalen Quellfluss zu erreichen.
- III. Hohe Einspritzgeschwindigkeit, um zügiges Füllen des Formteils zu gewährleisten; anschließend Nachdruck einstellen.

**EN**

**Graduated injection profile by machine**

- I. High injection speed for filling the cold runner.
- II. Low injection speed to ensure optimum frontal (laminar) flow.
- III. High injection speed for quick mold filling, followed by holding pressure setting.

**IT**

**Profilo d'iniezione graduato tramite macchina**

- I. Elevata velocità d'iniezione per il riempimento del canale di alimentazione freddo.
- II. Ridotta velocità d'iniezione per ottenere un flusso laminare ottimale.
- III. Elevata velocità d'iniezione per garantire un rapido riempimento del pezzo da stampare; regolare successivamente la pressione di mantenimento.

**2 Mechanisch gestuftes Einspritzprofil**

- > Querverteiler reduziert die Geschwindigkeit der Fließfront im Anschnittbereich bei konstanten Maschinenparametern.
- > für Werkzeuge, die häufig die Spritzgießmaschine wechseln.

**Mechanically graduated injection profile**

- > Transverse runner reduces the velocity of the flow front in the gate area while machine parameters remain constant.
- > For molds frequently used on different injection molding machines.

**Profilo d'iniezione graduato meccanicamente**

- > Il distributore trasversale riduce la velocità del fronte del flusso nella zona d'iniezione con parametri macchina costanti.
- > Per stampi che vengono impiegati spesso su diverse presse ad iniezione.

**Wärmeleitpaste · Heat sink paste · Pasta termoconduttiva**

**PE, PP, POM, PC, PBT, PEI, PPO, PS**

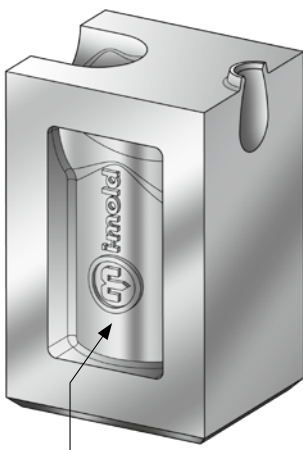

**Wärmeleitpaste**  
Heat sink paste  
Pasta termoconduttiva

**DE**

Bei der Verarbeitung von temperatur- und scherungsempfindlichen Materialien, sowie von Materialien, die zu „Fadenzug“ neigen, empfehlen wir, Wärmeleitpaste in die seitlichen Aussparungen einzubringen.

- > verhindert bei kurzen Zykluszeiten die lokale Erwärmung im Angusseinsatz.
- > verbessert die Wärmeabfuhr, so dass der Siegelpunkt früher erreicht werden kann.
- > verbessert den Abriss (kein Fadenzug; wichtig bei Polyolefinen)

Selbstverständlich können die Angusseinsätze auch ohne Wärmeleitpaste eingesetzt werden. Bei gewissen Anwendungsfällen kann durch das etwas höhere Temperaturniveau der Angusseinsätze eine längere Nachdruckzeit erreicht werden.

**EN**

When processing temperature-sensitive materials or plastics susceptible to “stringing”, we recommend the use of a heat sink paste in the lateral recesses.

- > Prevents localized heating of the gate insert in molding processes with short cycle times.
- > Improves heat dissipation so that the gate sealing point can be reached sooner.
- > Enhances degating performance (no stringing, important when processing polyolefins).

It goes without saying that these gate inserts can also be used without heat sink paste. In certain applications the somewhat higher insert temperature permits a longer holding pressure phase.

**IT**

Per la lavorazione di materiali sensibili alla temperatura e al taglio, nonché di materiali tendenti allo “sfilacciamento”, consigliamo l'applicazione di pasta termoconduttiva nelle nicchie laterali.

- > previene il riscaldamento locale nell'inserto d'iniezione durante una produzione con tempi brevi di ciclo;
- > migliora la dissipazione e del calore per un più rapido raggiungimento della temperatura di saldatura;
- > migliore distacco (nessun sfilacciamento); importante per le poliolefine).

Naturalmente gli inserti d'iniezione possono anche essere impiegati senza pasta termoconduttiva. In determinati casi si può ottenere un tempo di mantenimento più lungo tramite il livello di temperatura leggermente più elevato degli inserti d'iniezione.

# Ergänzende Tipps

Supplementary tips · Consigli supplementari

## TGC-XS / -S / -1 / -2 TGLL-1 / -2 TGML-1 / -2 TGHL-1 / -2

**Kalotten** · Vestiges · Calotta

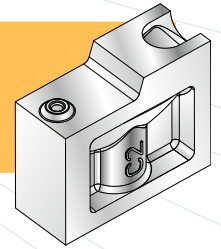

### Standard-Kalotte

Standard vestige · Calotta standard

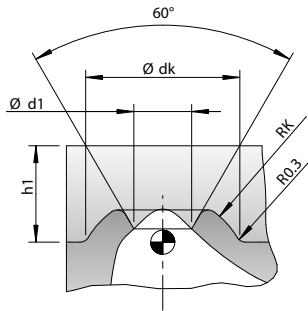

### Kleine Kalotte

Small vestige · Calotta piccola

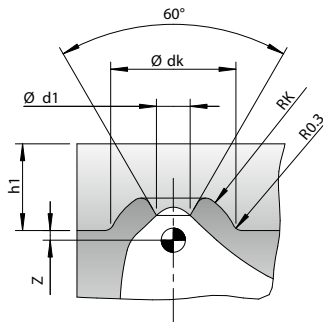

	Kalotte	h1	d1max.	dk	Rk	Z
TGC-XS	Standard	1.0	0.6	2.5	1.6	-
TGC-S	Standard	2.0	0.8	2.7	1.7	-
TGC-1 / TGLL-1 / TGML-1 / TGHL-1	Klein / Small / Piccolo	1.8	0.7	2.6	1.4	0.2
TGC-2 / TGLL-2 / TGML-2 / TGHL-2	Standard	2.0	1.2	3.2	1.8	-
TGC-2 / TGLL-2 / TGML-2 / TGHL-2	Klein / Small / Piccolo	2.75	1.2	3.5	2.0	0.25
TGC-2 / TGLL-2 / TGML-2 / TGHL-2	Standard	3.0	1.8	4.5	2.6	-



**Abstand Z zum CAD-Nullpunkt beachten!**

Maintain offset Z from CAD reference point!

Rispettare la distanza Z fino al punto zero CAD!

## TGC-3 / -4 TGLL-3 TGML-3 TGHL-3

**Kalotten** · Vestiges · Calotta

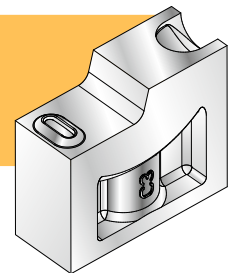

### Standard-Kalotte

Standard vestige · Calotta standard

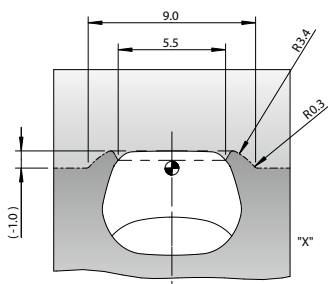
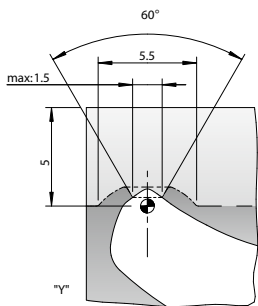

### Kleine Kalotte

Small vestige · Calotta piccola

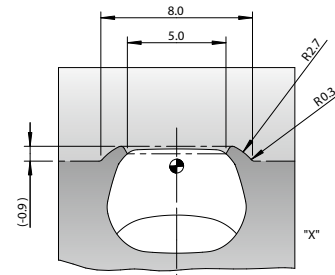
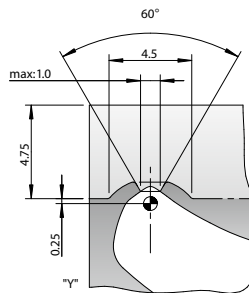

## Kalotten-Varianten · Vestige versions · Versioni di calotte

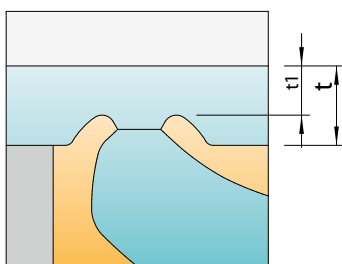

**Kugelförmige Kalotte mit Kegel**  
Spherical vestige with cone  
Calotta sferica con cono

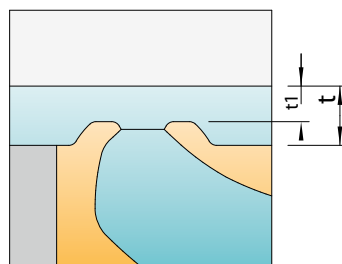

**Abgeflachte Kalotte mit Kegel**  
Flattened vestige with cone  
Calotta piatta con cono

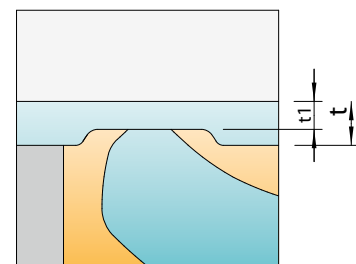

**Abgeflachte Kalotte ohne Kegel**  
Flattened vestige without cone  
Calotta piatta senza cono

$t_1 > t/2$   $t$  = Wandstärke des Kunststoffteils /  $t$  = wall thickness of plastic part /  $t$  = spessore parete del pezzo in plastica

**Anschnitt Erodieren\*** · Spark erosion of gate area · Electroerosione del punto d'iniezione

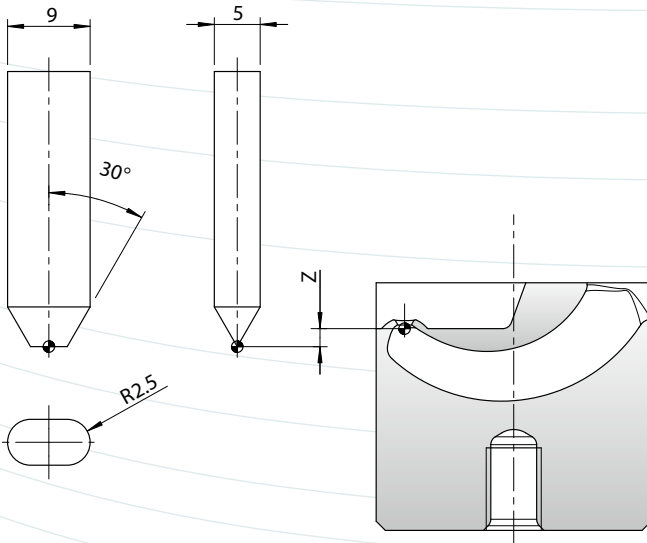

**DE Fertigung des Anschnitts mittels Elektrode**

- > einfaches Platzieren der Elektrode über Koordinatensystem
- > 2D- und 3D- Geometrie der Elektrode unter [www.i-mold.de](http://www.i-mold.de) (Downloadbereich)

**EN Gate machining by spark erosion**

- > Simple positioning of electrode via coordinate system
- > For 2D and 3D electrode geometry please refer to [www.i-mold.com](http://www.i-mold.com) (download section)

**IT Realizzazione del punto d'iniezione tramite elettrodo**

- > facile posizionamento dell'elettrodo tramite un sistema di coordinate
- > geometria 2D e 3D dell'elettrodo presso [www.i-mold.com](http://www.i-mold.com) (area di download)

**Anschnitt Fräsen\*** · Milling of gate area · Fresatura del punto d'iniezione

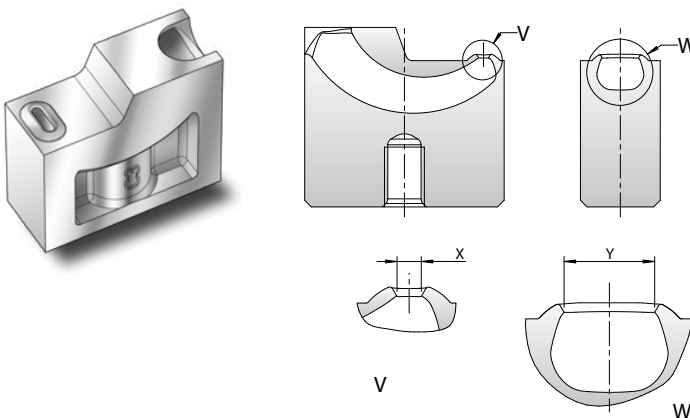

**DE Fertigung des Anschnitts mittels Fräsen**

- > einfaches Fertigen des Anschnitts über Verfahren in Y und Z-Achse

**EN Gate machining by milling**

- > Easy milling of gate area via Y and Z-axis travel

**IT Realizzazione del punto d'iniezione tramite fresatura**

- > semplice realizzazione del punto d'iniezione tramite traslazione negli assi Y e Z

\*TGC 3+4 / TGLL-3 / TGML-3 / TGHL-3

	<b>Anschnitt Erodieren</b> Spark erosion of gate area Electroerosione del punto di iniezione		<b>Anschnitt Fräsen</b> Milling of gate area Fresatura del punto d'iniezione	
<b>Querschnittsfläche [mm<sup>2</sup>]</b> Cross-sectional area [mm <sup>2</sup> ] Superficie trasversale [mm <sup>2</sup> ]	<b>Elektrodentiefe Z [mm]</b> Electrode depth Z [mm] Profondità elettrodo Z [mm]	<b>Breite X [mm]</b> Width X [mm] Larghezza X [mm]	<b>Länge Y [mm]</b> Length Y [mm] Lunghezza Y [mm]	
7,60	-0,86	1,5	5,5	
7,00	-0,74	1,4	5,4	
6,41	-0,62	1,3	5,3	
5,84	-0,49	1,2	5,2	
5,27	-0,37	1,1	5,1	
4,72	-0,25	1,0	5,0	
4,18	-0,13	0,9	4,9	
3,65	-0,01	0,8	4,8	
3,13	+0,11	0,7	4,7	
2,63	+0,23	0,6	4,6	
2,14	+0,35	0,5	4,5	

# Einbau TGC / TGLL / TGML / TGHL

Installation · Montaggio TGC / TGLL / TGML / TGHL

# 1

## CAD-Nullpunkt

CAD reference point  
Punto zero CAD

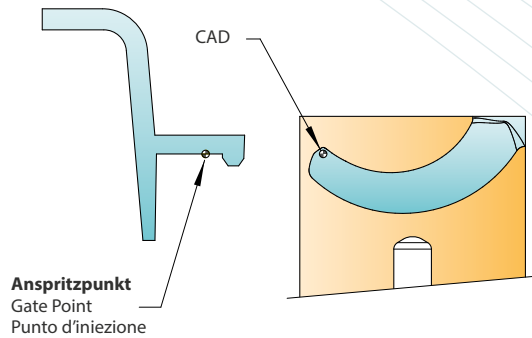

# 2

## Angusseinsatz positionieren

Position the tunnel gate insert  
Posizionare l'inserto d'iniezione

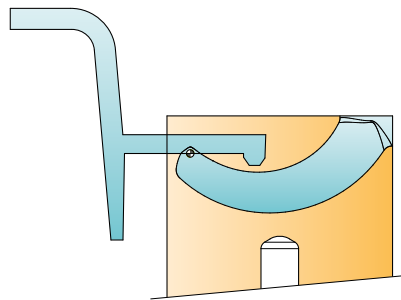

### Konturfläche der Kalotte in 3D-Daten enthalten

Contour surface of the vestige is contained in the 3D data

La superficie di contornatura della calotta è inclusa nei dati 3D

# 3

## Teilekontur und Kalotte abziehen\*

Deduct the part's contour and vestige\*

Togliere il contorno del pezzo e la calotta\*

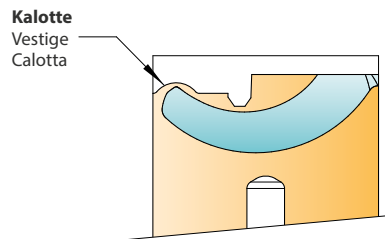

# 4

## Angusskanal anpassen\*

Adapt the feed channel\*

Adattare il canale d'iniezione\*

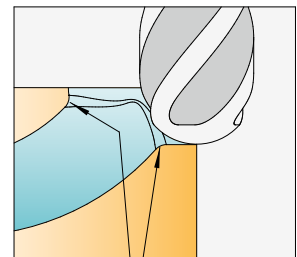
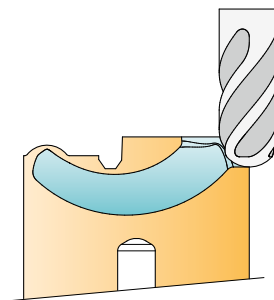

Übergänge verrunden\*  
Round off the transitions\*  
Arrotondare i passaggi\*

# 5

## Anschnitt bearbeiten

Machine the gate

Lavorare il punto d'iniezione

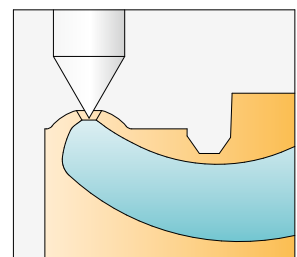
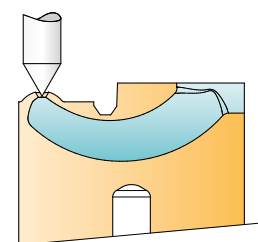

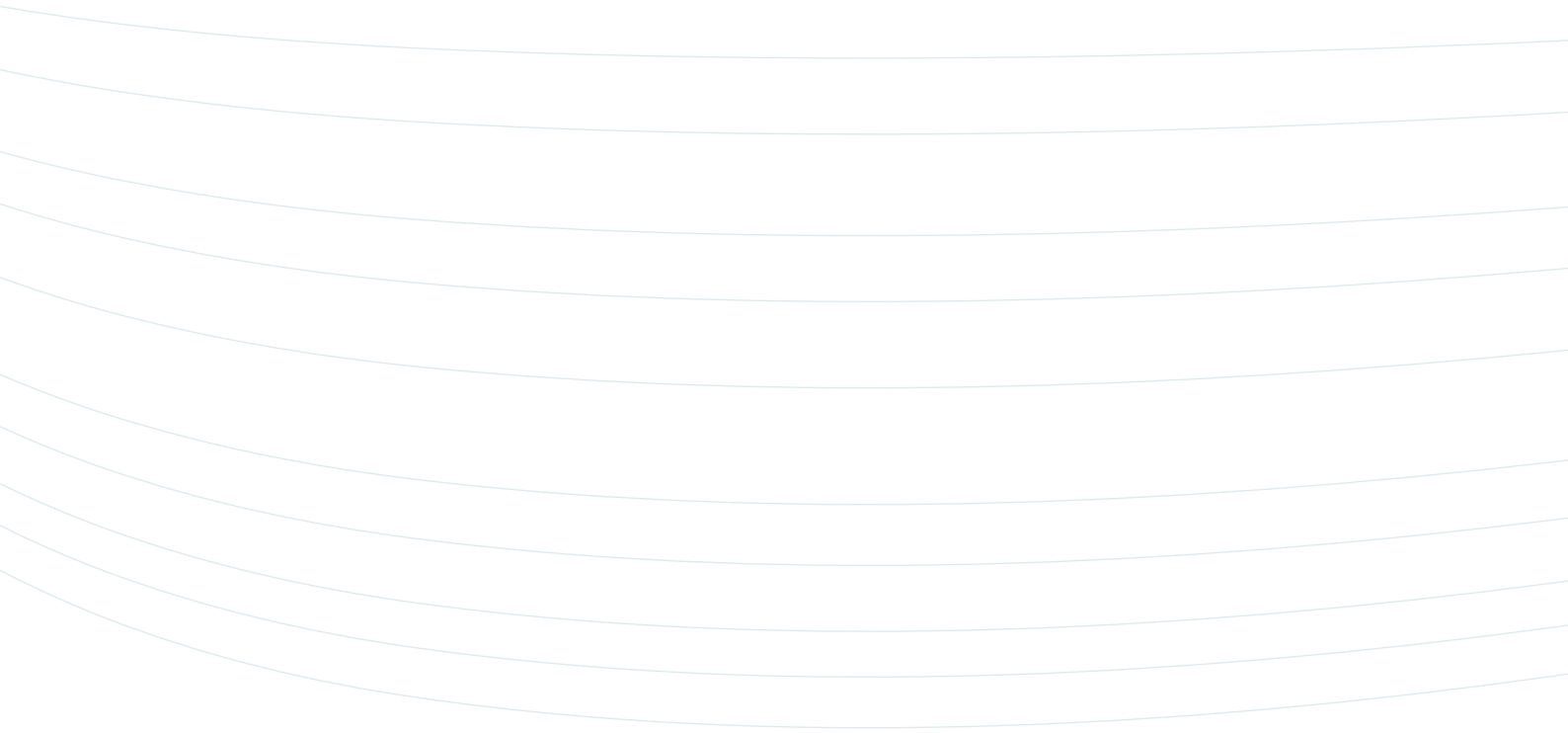



**i-mold**  
MOLDING INNOVATIONS

[www.i-mold.de](http://www.i-mold.de)

[www.i-mold.com](http://www.i-mold.com)

i-mold GmbH & Co. KG  
Gewerbepark Gräsig 72  
D-64711 Erbach

Tel.: +49 (0) 6062 80933-0  
Fax: +49 (0) 6062 80933-30  
[info@i-mold.com](mailto:info@i-mold.com)

M O L D I N G I N N O V A T I O N S