

4

Precyzyjne akcesoria do form *Pre-engineered components for molds*



Spis treści

Table of contents

SPIS TREŚCI

Table of contents

4.5	Obsada słupa skośnego <i>Angle pin retainer</i>		MS40
4.6	Obsada ze słupem skośnym <i>Retainer with angle pin</i>		MS401
4.8	Zespół suwaka <i>Mold slide unit</i>		MS41
4.9	Obsada wypychacza skośnego <i>Slide for angular expulsion</i>		MS42
4.12	Zamek górny <i>Top lock</i>		MS521
4.13	Zamek górny <i>Top lock</i>		MS522
4.14	Zamek boczny <i>Side lock</i>		MS50
4.15	Zamek boczny <i>Side lock</i>		MS51
4.16	Zespół centrujący <i>Centering unit</i>		ZCA

Spis treści

Table of contents

4.17 **Pierścień dystansowy**
Compensating disc



PZC

4.18 **Zatrzaski do form wtryskowych**
Slide locks



SLK

4.20 **Zawór powietrzny**
Air valve



VA

4.21 **Licznik do form**
CounterView



CVPL-200

Obsada słupa skośnego

Angle pin retainer

MS40

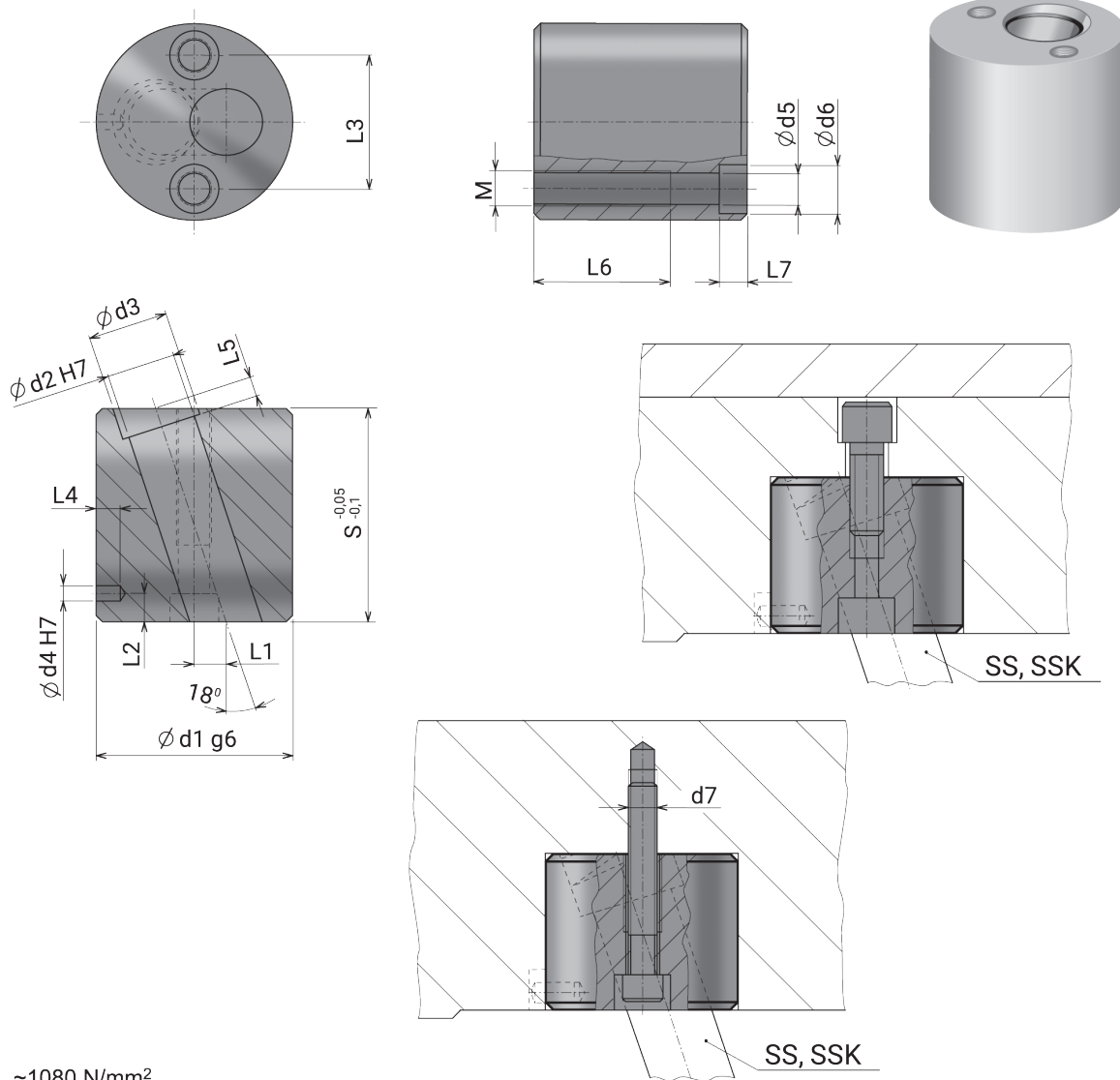

~1080 N/mm²

d1	d2	S	d3	d4	d5	d6	M	d7	L1	L2	L3	L4	L5	L6	L7	NR KAT.
32	10	27	13	4	5,2	9	M6	M5	4,5	4	21	6	3	15	5,5	MS40-3210
36	12	36	17						6		25		6			MS40-3612
	14		19	8	8	MS40-3614										
42	16	46	21	5	6,8	11	M8	M6	8	6	29	8	8	20	8,5	MS40-4216
48	18		23						8,5		34					MS40-4818
	54	20	25	6	8,5	13,5	M10	M8	11	7	36	10	15	20	10,5	MS40-4820
22		27	MS40-5422													
60	24	66	29	8	8,5	13,5	M10	M8	11	8	44,5	12	15	20	10,5	MS40-5424
	30		37													MS40-6030

Obsada ze słupem skośnym

Retainer with angle pin

MS401

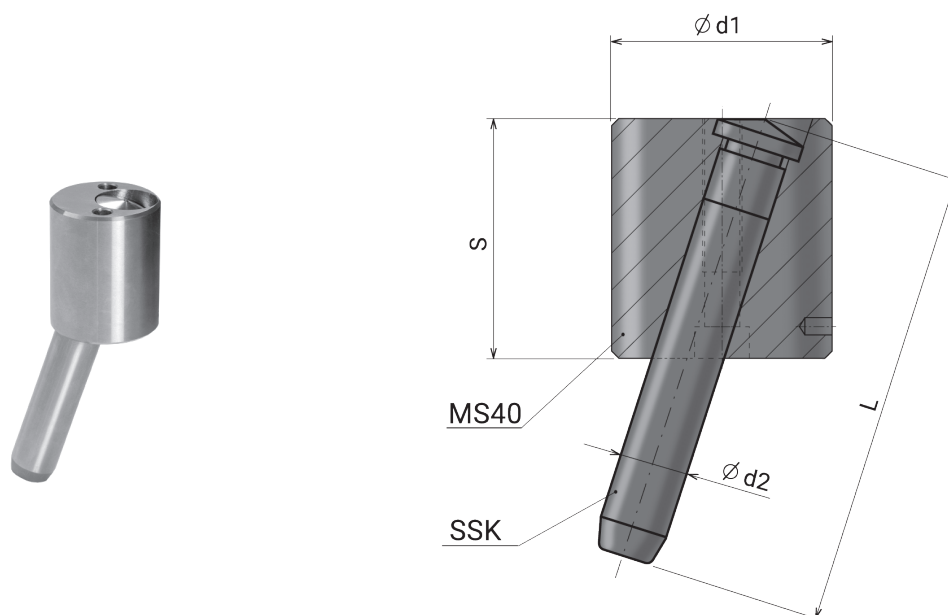

MS40	SSK	d1	S	d2	L	NR KAT.
MS40-3210	SSK-10040	32	27	10	40	MS401-3210040
	SSK-10060				60	MS401-3210060
	SSK-10080				80	MS401-3210080
	SSK-10100				100	MS401-3210100
	SSK-10120				120	MS401-3210120
MS40-3612	SSK-12060	36	36	12	60	MS401-3612060
	SSK-12080				80	MS401-3612080
	SSK-12100				100	MS401-3612100
	SSK-12120				120	MS401-3612120
	SSK-12140				140	MS401-3612140
	SSK-12160				160	MS401-3612160
MS40-3614	SSK-14060	36	36	14	60	MS401-3614060
	SSK-14080				80	MS401-3614080
	SSK-14100				100	MS401-3614100
	SSK-14120				120	MS401-3614120
	SSK-14140				140	MS401-3614140
	SSK-14160				160	MS401-3614160
	SSK-14180				180	MS401-3614180
MS40-4216	SSK-16060	42	46	16	60	MS401-4216060
	SSK-16080				80	MS401-4216080
	SSK-16100				100	MS401-4216100
	SSK-16120				120	MS401-4216120
	SSK-16140				140	MS401-4216140
	SSK-16160				160	MS401-4216160
	SSK-16180				180	MS401-4216180
	SSK-16200				200	MS401-4216200

Obsada ze słupem skośnym
Retainer with angle pin

MS401

MS40	SSK	d1	S	d2	L	NR KAT.
MS40-4818	SSK-18060	48	46	18	60	MS401-4818060
	SSK-18080				80	MS401-4818080
	SSK-18100				100	MS401-4818100
	SSK-18120				120	MS401-4818120
	SSK-18140				140	MS401-4818140
	SSK-18160				160	MS401-4818160
	SSK-18180				180	MS401-4818180
	SSK-18200				200	MS401-4818200
	SSK-18240				240	MS401-4818240
MS40-4820	SSK-20080	48	46	20	80	MS401-4820080
	SSK-20100				100	MS401-4820100
	SSK-20120				120	MS401-4820120
	SSK-20140				140	MS401-4820140
	SSK-20160				160	MS401-4820160
	SSK-20180				180	MS401-4820180
	SSK-20200				200	MS401-4820200
	SSK-20240				240	MS401-4820240
MS40-5422	SSK-22080	54	66	22	80	MS401-5422080
	SSK-22100				100	MS401-5422100
	SSK-22120				120	MS401-5422120
	SSK-22140				140	MS401-5422140
	SSK-22160				160	MS401-5422160
	SSK-22180				180	MS401-5422180
	SSK-22200				200	MS401-5422200
	SSK-22220				220	MS401-5422220
	SSK-22240				240	MS401-5422240
	SSK-22300				300	MS401-5422300
	MS40-5424				SSK-24080	54
SSK-24100		100	MS401-5424100			
SSK-24120		120	MS401-5424120			
SSK-24140		140	MS401-5424140			
SSK-24160		160	MS401-5424160			
SSK-24180		180	MS401-5424180			
SSK-24200		200	MS401-5424200			
SSK-24220		220	MS401-5424220			
SSK-24240		240	MS401-5424240			
SSK-24300		300	MS401-5424300			
MS40-6030		SSK-30100	60	66	30	
	SSK-30120	120				MS401-6030120
	SSK-30160	160				MS401-6030160
	SSK-30200	200				MS401-6030200
	SSK-30240	240				MS401-6030240
	SSK-30300	300				MS401-6030300
	SSK-30360	360				MS401-6030360

Zespół suwaka

Mold slide unit

MS41

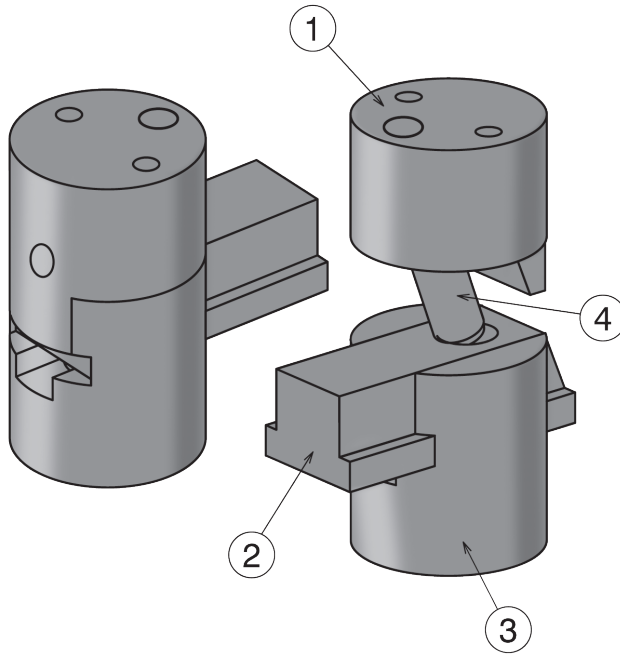

Część Part	Mat.	Obróbka cieplna Treatment
1	1.2312	Azotowane Nitrided
2	1.2343	Hartowane Hardened HRC 52-54
3	1.2312	Azotowane Nitrided
4	C53	Hartowane Hardened HRC 61 -64

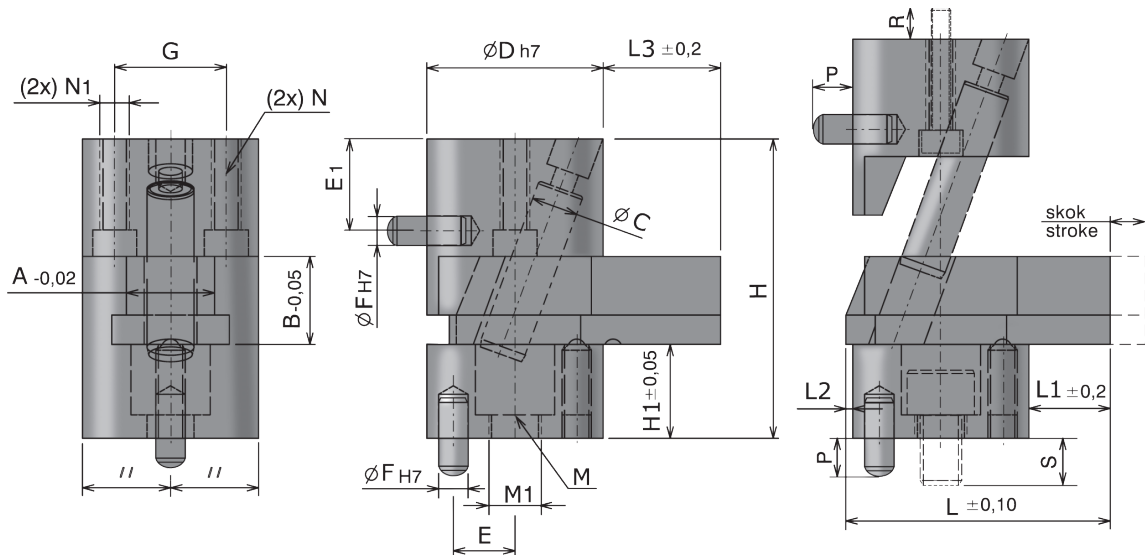

NR KAT.	A	B	C	D	E	E1	F	G	H	H1	L	L1	L2	L3	M	M1	N	N1	P	R	S	skok stroke
MS41-22	10	10	∅6	∅22	7,5	11,5	∅4H7	14	35,5	10	35	13,1	~0,2	15	M5x12	M5	M3x20	M4	~5	~8	8	~2,4
MS41-30	15	15	∅8	∅30	10,5	15,5	∅5H7	19	51	16	45	14,7	~0,3	20	M6x16	M8	M4x25	M5	~9	~10	9	~5,3
MS41-35	20	20	∅10	∅35	13	15,5	∅5H7	24	63	23	55,5	17,5	~3,0	25,5	M8x20	M10	M5x25	M6	~9	~11	12	~8,0

Zastrzegamy sobie prawo do zmian bez uprzedzenia. Zawsze sprawdzaj aktualność katalogu na stronie www.proplastica.pl
We reserve the right to amend this catalogue without notice. Always check www.proplastica.pl for latest updates.

Obsada wypychacza skośnego

Slide base for angle ejection

MS42

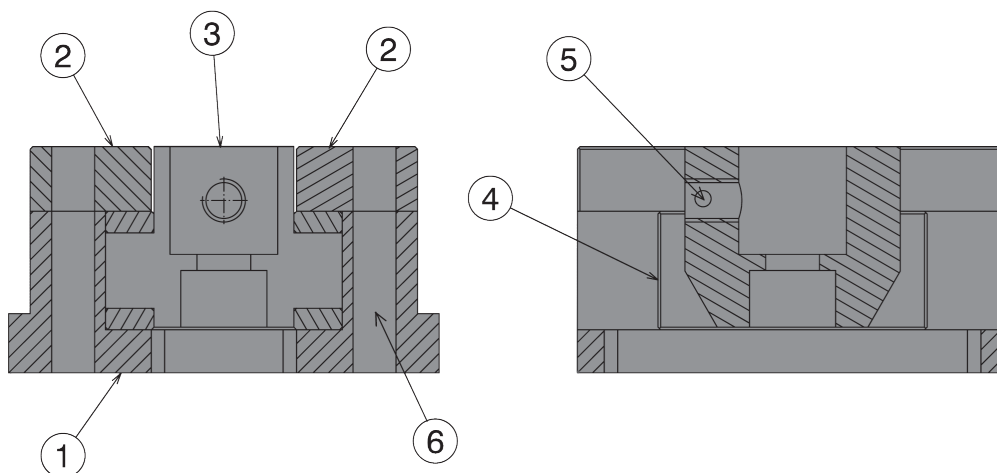

Przykłady instalacji

Examples of installation

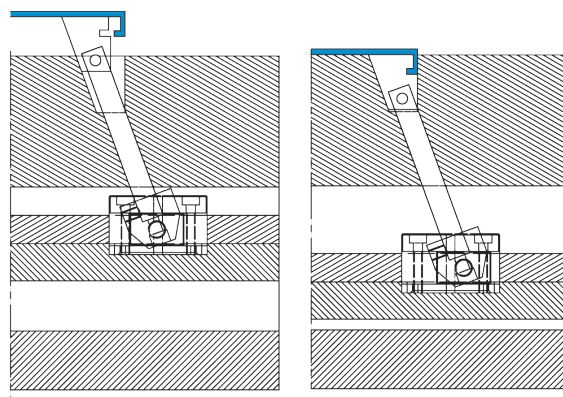
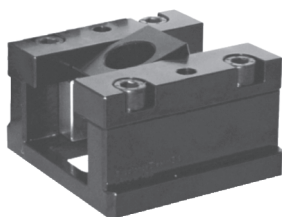

Części składowe

List of parts

Część Part	Ilość quantity	Mat.
1	1	1.2312
2	2	1.2312
3	1	1.2312
4	2	Brąz / Bronze 1.714
5	1	DIN 913
6	4	DIN 7984

Jednostka ta umożliwia pochylenie w zakresie kątów $\pm 30^\circ$ i może pracować przy wypychaniu skomplikowanych detali. Można ją montować między płytami wypychaczy lub poza nimi bez ograniczania ich funkcji i dzięki temu zapewnia optymalne wykorzystanie przestrzeni. Prowadnice ślizgowe wykonano z brązu w celu zmniejszenia tarcia.

Sliding system providing tilt varying between $\pm 30^\circ$, this component is suitable for more sophisticated internal handling operations. The mechanism can be installed between the two ejector plates and outside without compromising their function. This mechanism enables utilising most of the space available also bronze plates are used to reduce friction.

Obsada wypychacza skośnego

Slide base for angle ejection

MS42

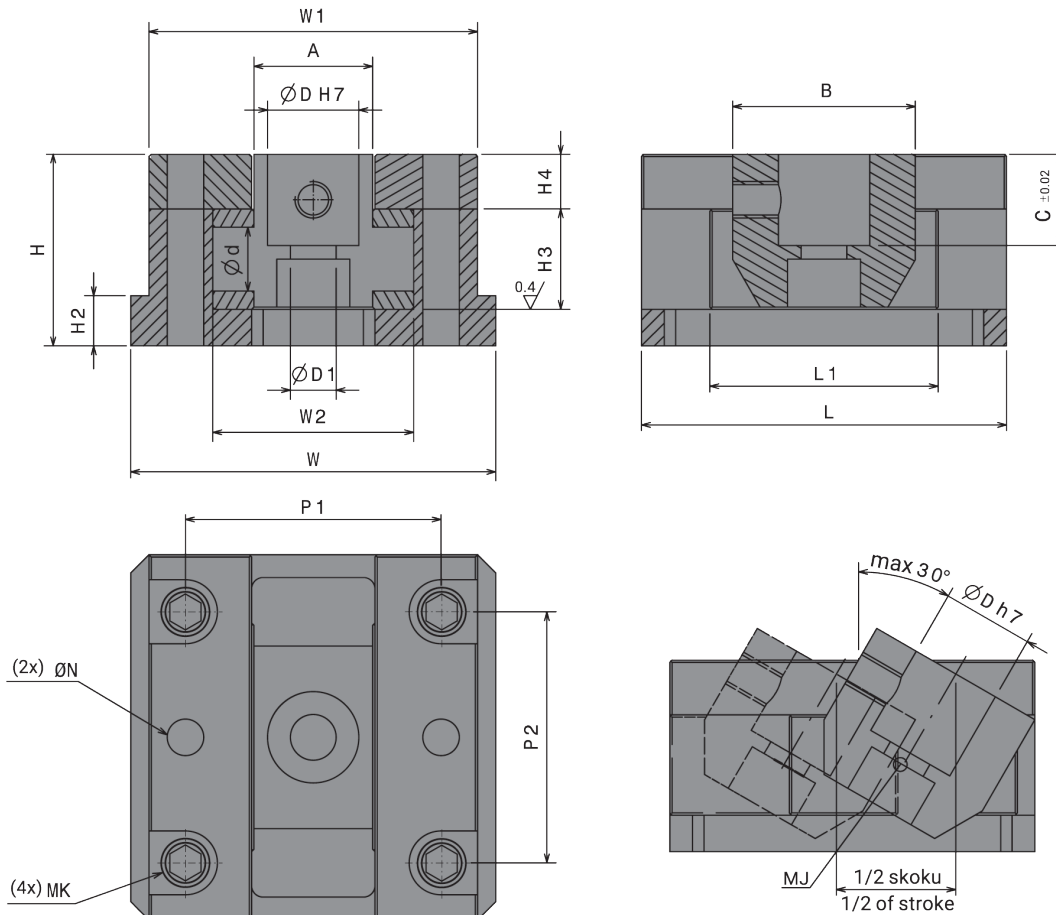
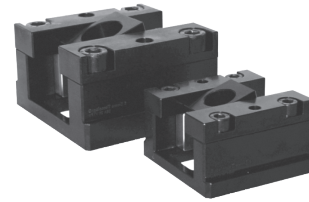

NR KAT.	D	d	D1	A	B	C	MJ	H	H2	H3	H4	L	L1	W	W1	W2	P1	P2	MK	N	skok stroke
MS42-08	8	7	4.5	11	20	8	M4	22	5	11	7	32	20	33	30	19	24	20	M3	3	10
MS42-10	10	7	5.5	15	25	10	M5	27	5	15	8	45	25	45	40	25	32	30	M4	4	18
MS42-12	12	10	7	17	25	12	M6	32	7	16	10	50	30	57	51	31	39	35	M5	6	20
MS42-16	16	12	9	22	30	16	M6	36	8	20	10	65	40	65	58	38	46	40	M6	6	25
MS42-20	20	14	11	26	40	20	M10	42	11	22	12	80	50	80	72	44	56	55	M8	8	30
MS42-25	25	16	14	32	45	25	M12	50	15	26	15	90	55	93	85	52	66	65	M10	10	35
MS42-30	30	18	14	38	50	30	M12	55	15	30	15	100	60	101	93	60	74	70	M10	10	40
MS42-35	35	20	14	45	60	35	M12	65	15	34	18	120	75	120	110	70	85	80	M12	10	45
MS42-40	40	25	18	55	70	40	M16	70	15	44	18	135	85	130	120	80	95	90	M12	10	50
MS42-45	45	30	18	60	80	45	M16	80	15	50	20	150	95	140	130	90	105	110	M12	10	55

Zamek górny

Top lock

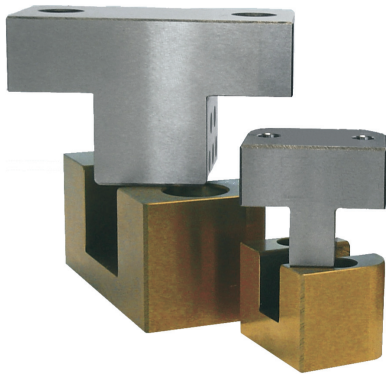

Zamki górne zapewniają precyzyjne wzajemne pozycjonowanie płyt formujących. Ustawiają one i utrzymują płyty w jednej osi i pochłaniają rozszerzenia wzdłużne w tym kierunku. Wykonanie wybrań pod zamki górne odbywa się w każdej płycie formującej jednocześnie z obróbką gniazd formujących co gwarantuje dużą dokładność. „Męska” część zamka posiada wkładki grafitowe a „żeńska” jest pokryta TiN co zapewnia stałe smarowanie podczas pracy.

These centring devices enable proper alignment of the main die plates to be guaranteed. The parallel centring device keeps the axis on which it is fixed stable, and in turn absorbs the lengthways expansion of this same axis. All machining operations are in a vertical direction for the plate and cut outs for for the centring devices and are made at the same time so high precision is achieved. The entire range is constructed with graphite inserts in the male part of the centring device while the female part is covered with tin, which allows for constant auto-lubrication during operation.

Zamek górny

Top lock

MS521

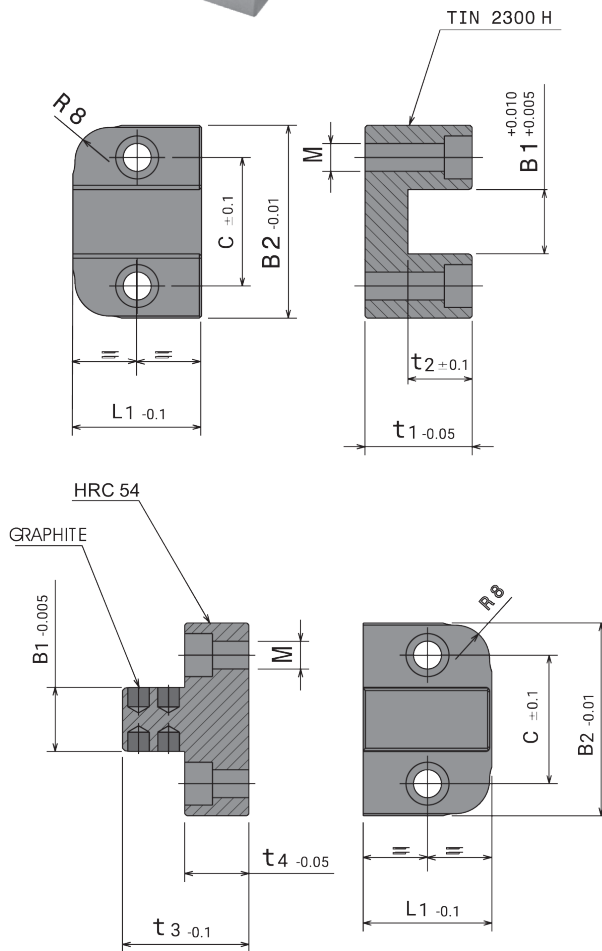
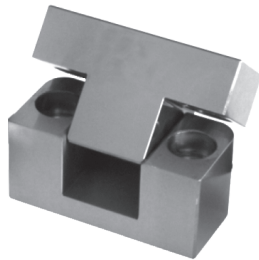

Mat.	1.2312
Obróbka cieplna <i>Treatment</i>	Hartowane <i>Hardened</i> HRC 52-54
Pokrycie <i>Coating</i>	TIN
	Grafit <i>Graphite</i>

Przykłady instalacji

Examples of installation

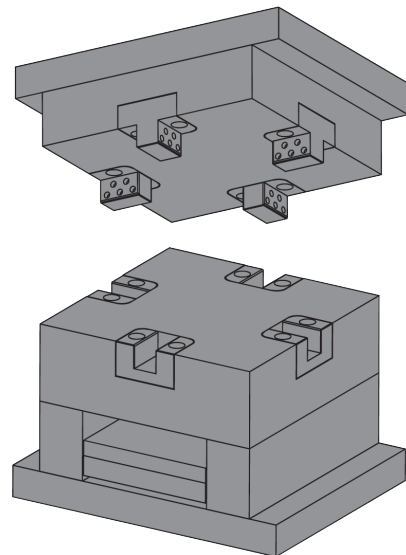

NR KAT.	B1	B2	L1	C	t1	t2	t3	t4	M
MS521-035	11	35	26	23	25	14,5	29	15	M5
MS521-045	15	45	30	30	25	14,5	29	15	M6
MS521-055	20	55	36	37,5	30	19,5	39	20	M8
MS521-075	30	75	36	52	35	24,5	44	20	M10
MS521-100	40	100	45	70	60	39,5	59	20	M10
MS521-125	60	125	50	92,5	80	54,5	79	25	M14

Zastrzegamy sobie prawo do zmian bez uprzedzenia. Zawsze sprawdzaj aktualność katalogu na stronie www.proplastica.pl
We reserve the right to amend this catalogue without notice. Always check www.proplastica.pl for latest updates.

Zamek górny

Top lock

MS522-18

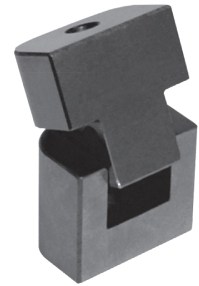
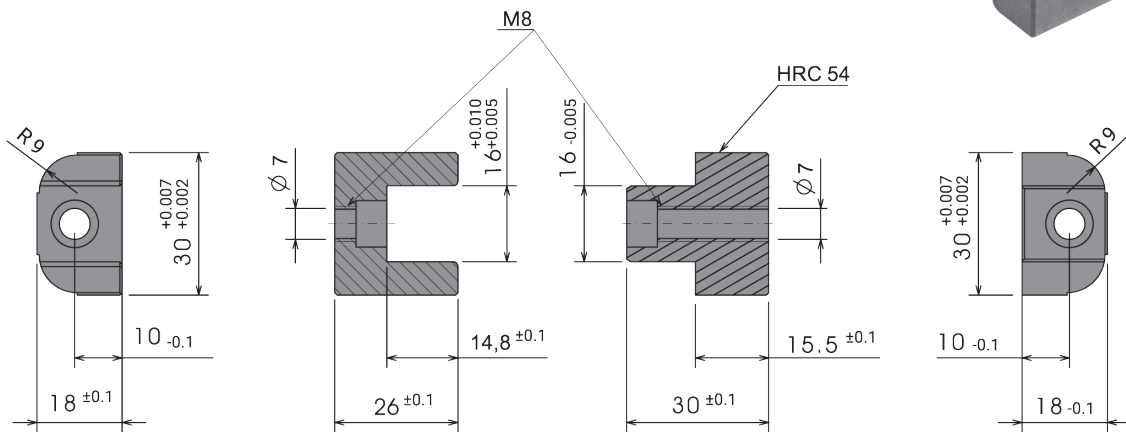

Zamek górny

Top lock

MS522-38

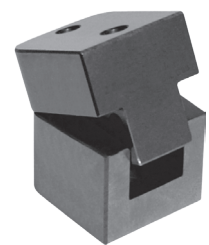
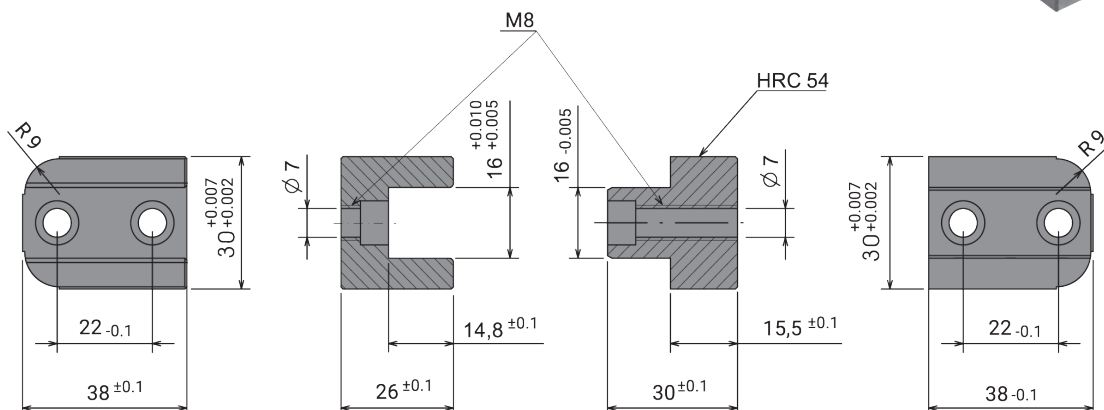

Zamek boczny

Side lock

MS50

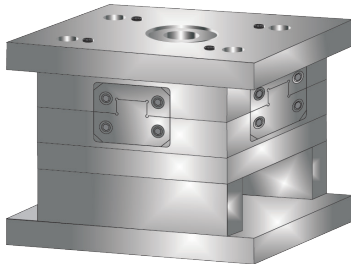

Część „A”
Part „A”

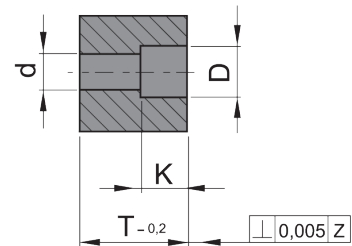
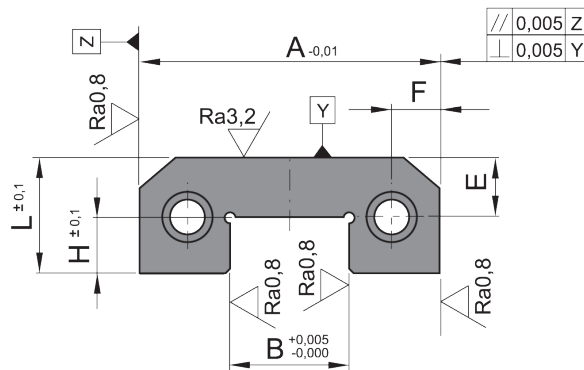

Część „B”
Part „B”

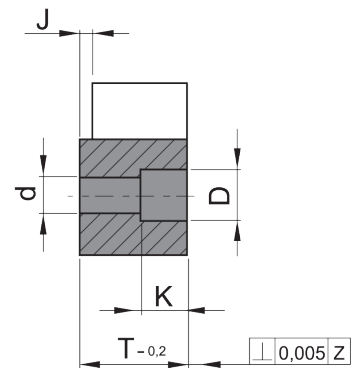
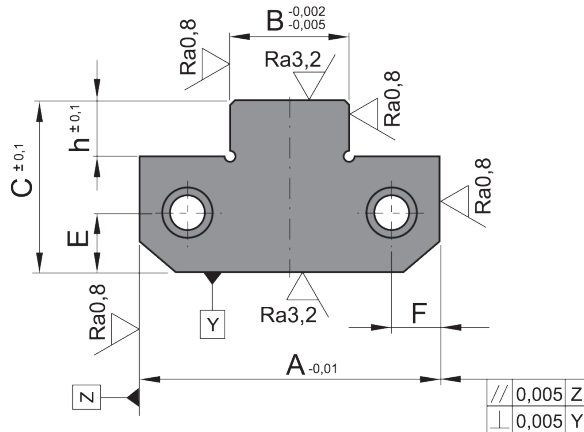

Twardość / hardness
„A” 55-60 HRC
„B” 50-55 HRC

A	B	C	D	d	E	F	h	H	J	K	L	T	NR KAT.
50	17	30	10,5	6,5	11	8	8,5	9,5	1,5	8	21,5	16	MS50-050
75	25	50	16,5	10,5	18	12,5	14	15		12	36	19	MS50-075
100	35	65			22	15	20	21	MS50-100				
125	45				20,5				MS50-125				

Zamek boczny

Side lock

MS51

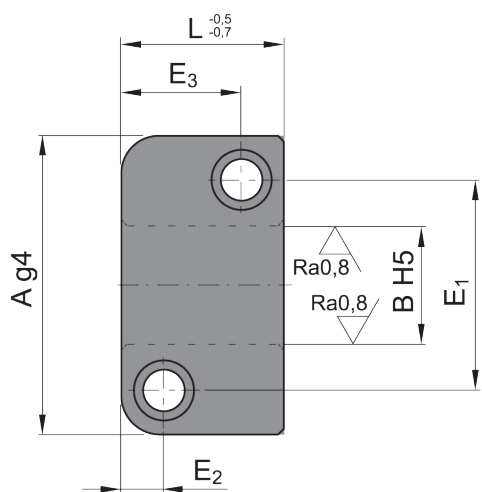
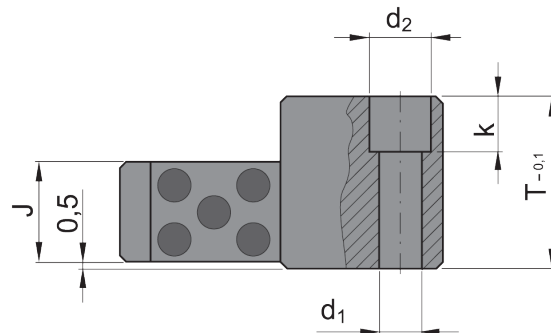
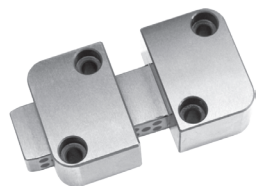

Część „A”
Part "A"

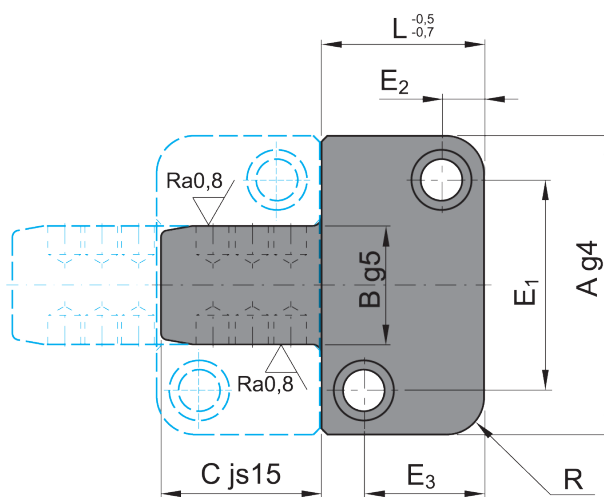

Część „B”
Part "B"

Twardość / hardness
„A” 58-60 HRC
„B” 54-56 HRC

L	C	A	T	B	J	E1	E2	E3	R	d1	d2	k	NR KAT.
22	20	40	20	16	11	26	7	15	6	6,6	11	6,8	MS51-22020
	40												MS51-22040
27	25	45	22	20	13	31	7	19	6	6,6	11	6,8	MS51-27025
	50												MS51-27050
36	32	50	25	25	14	35	9	27	8	6,6	11	6,8	MS51-36032
	63												MS51-36063
46	40	63	32	32	19	45	11	35	8	9	15	9	MS51-46040
	80												MS51-46080
56	50	85	36	40	22	60	15	40	10	11	18	11	MS51-56050
	100												MS51-56100
66	56	100	40	50	24	74	18	48	10	14	20	13	MS51-66056
	112												MS51-66112

Zespół centrujący

Centering unit

ZCA

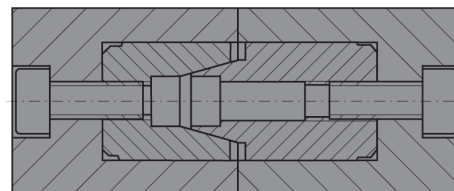
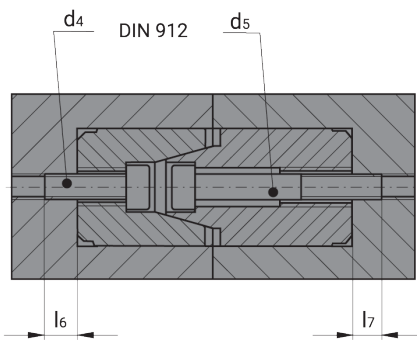
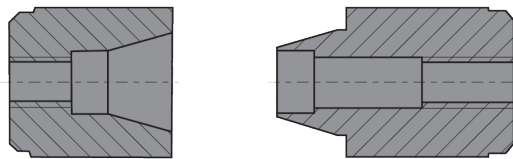
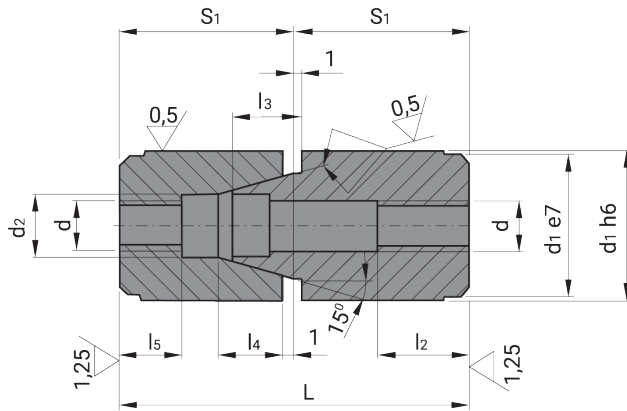

Twardość / hardness
60±2HRC

S1	d	d4	d5	l7	l6	l5	l4	l3	l2	L	d2	d1	NR KAT.		
17	M4	M3x16	M3x25	8,0	7,5	8,5	5	4,5	9,6	34	6	12	ZCA-12		
	M5	M4x14	M4x25	7,5	8,0	6,0	7	6	12,4		8	14	ZCA-14		
						5,8						16	ZCA-16		
27	M8	M6x20	M6x40	12	9,5	10,6	10	9	19,7	54	11	20	ZCA-20		
				11			11					9,2	11	10	25
								26				ZCA-26			
36	M10	M8x25	M8x55	15	13	12,2	16	14	25	72	14	30	ZCA-30		
46		M8x30	M8x70	16		16,8	20	18				27	92	42	ZCA-42

Zastrzegamy sobie prawo do zmian bez uprzedzenia. Zawsze sprawdzaj aktualność katalogu na stronie www.proplastica.pl
We reserve the right to amend this catalogue without notice. Always check www.proplastica.pl for latest updates.

Pierścień dystansowy

Compensating disc

PZC

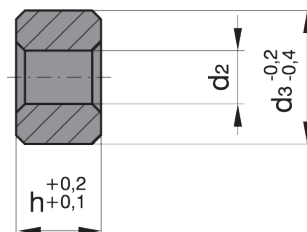

Twardość / hardness
50±2HRC

d2	d3	h	NR KAT.
4,5	12	10	PZC-1210
5,5	14	5	PZC-1405
		10	PZC-1410
		14	PZC-1414
		19	PZC-1419
	16	5	PZC-1605
		10	PZC-1610
19		PZC-1619	
9	20	9	PZC-2009
		10	PZC-2010
		20	PZC-2020
	25	9	PZC-2509
		10	PZC-2510
		20	PZC-2520
	26	9	PZC-2609
		10	PZC-2610
		20	PZC-2620
		30	PZC-2630
11	30	10	PZC-3010
		20	PZC-3020
		30	PZC-3030
	32	10	PZC-3210
		20	PZC-3220
	42	10	PZC-4210
		20	PZC-4220
		30	PZC-4230

Zatrzaski do form wtryskowych

Slide-locks

SLK

SLK-8A



FPCPK Bytów Sp. z o.o. jako wyłączny przedstawiciel w Polsce amerykańskiej firmy Die Set Corporation oferuje zatrzaski do form SLIDE-LOCK typ SLK-8A, SLK-25A i SLK-50A objęte patentem nr 4,765, 585. W ramach naszej oferty zapewniamy kompletne zatrzaski wraz z metrycznymi śrubami montażowymi. Siła zamknięcia dla jednego zatrzasku SLIDE-LOCK typ SLK-8A wynosi 8 funtów (ok. 35 N), dla typu SLK-25A wynosi 25 funtów (ok. 112 N), a dla typu SLK-50A wynosi 50 funtów (ok. 223 N) bez wspomagania hydraulicznego lub innego rodzaju. Aby osiągnąć większą siłę zamknięcia można zastosować kilka zatrzasków SLIDE-LOCK. Dzięki prostej budowie zatrzaski SLIDE-LOCK nie wymagają konserwacji, a ich montaż jest bardzo łatwy i dlatego mogą być również zastosowane w formach już użytkowanych. Zastosowanie do produkcji SLIDE-LOCK wysokiej jakości materiałów oraz odpowiednia ich obróbka cieplna zapewnia dużą trwałość tych zatrzasków w eksploatacji.

FPCPK Bytów Sp. z o.o. as an exclusive distributor of Superior Die Set Corporation of Milwaukee, WI, USA in Poland offers you Slide Locks models SLK-8A, SLK-25A and SLK-50A, patent #4,765,585. We deliver a complete Slide-Lock set supplied with metric mounting socket head cap screws. Slide-Lock SLK-8A holds up to 8 lbs. (ca. 35N), SLK-25A holds up to 25 lbs. (ca. 112N) and SLK-50A is rated to carry a weight up to 50 lbs. (ca. 223N) without hydraulics or other complicated devices. Multiple Slide-Locks can be utilized to achieve greater weight retention. Simple, rugged design is virtually maintenance free. Slide-Locks are recessed into slide for neat installation and can be retrofitted into your existing slides. Assembly made from quality materials and hardened for continuous production durability.

SLK-25A i SLK-50A



TYP / Model	Siła zamknięcia / Hold
SLK-8A	35 N
SLK-25A	112 N
SLK-50A	223 N

Zamontowanie zatrzasku typu SLIDE-LOCK w formie powinno być takie, aby przy pełnym wysunięciu słupa skośnego wzajemne usytuowanie elementów zatrzasku zawarte było w przedziale:

- a) dla SLK-8A $k=0,020 \div 0,030$ " (~0,5÷0,75 mm)
- b) dla SLK-25A $k=0,050 \div 0,075$ " (~1,25÷1,9 mm)
- c) dla SLK-50A $k=0,075 \div 0,100$ " (~1,9÷2,54 mm)

Note: Set angle pin to release.
 a) $k=0.020 \div 0.030$ " (~0.5÷0.75 mm) for SLK-8A
 b) $k=0.050 \div 0.075$ " (~1.25÷1.9 mm) for SLK-25A
 c) $k=0.075 \div 0.100$ " (~1.9÷2.54 mm) for SLK-50A
 for full stroke. Slide-Lock will snap to full stroke to assure re-entry clearance.

Elementy zatrzasku SLIDE-LOCK są montowane w osiach skoku suwaka formy.

Place Slide-Lock from centerline to centerline of stroke.

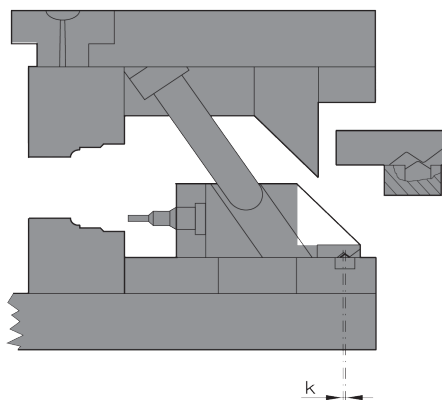
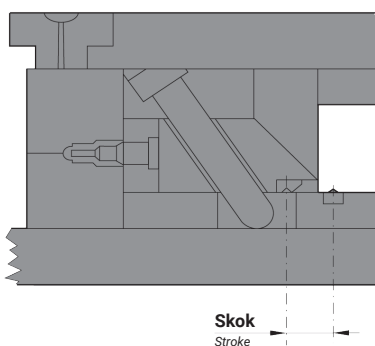

Zatrzaski do form wtryskowych

Slide-locks

SLK

Dane montażowe slide-lock typ SLK-8A

SLK-8A machining data.

Montaż zatrzasku

Holder assembly.

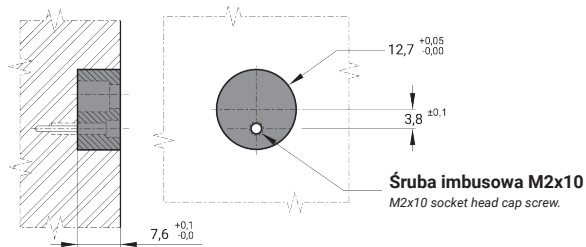

Montaż płytki ustalającej

Latch assembly.

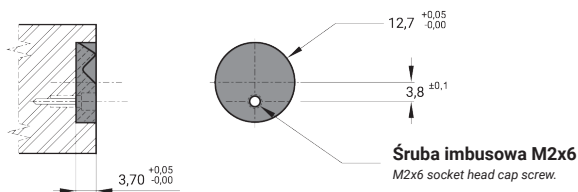

Wzajemne usytuowanie elementów SLK-8A po montażu.

Assembly reference.

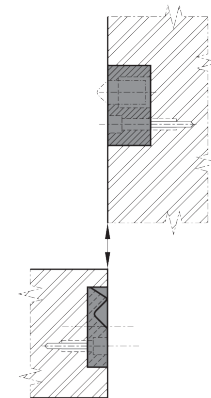

Dane montażowe slide-lock typ SLK-25A

SLK-25A machining data.

Montaż zatrzasku

Holder assembly.

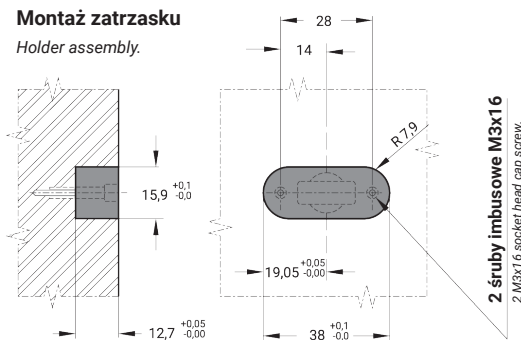

Montaż płytki ustalającej

Latch assembly.

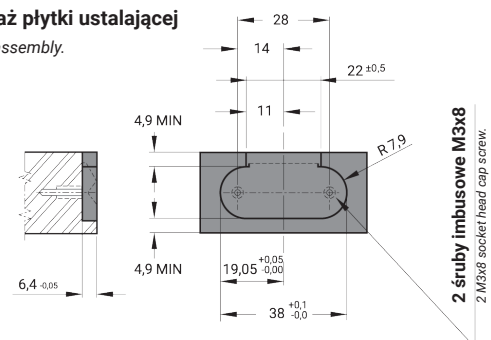

Dane montażowe slide-lock typ SLK-50A

SLK-50A machining data.

Montaż zatrzasku

Holder assembly.

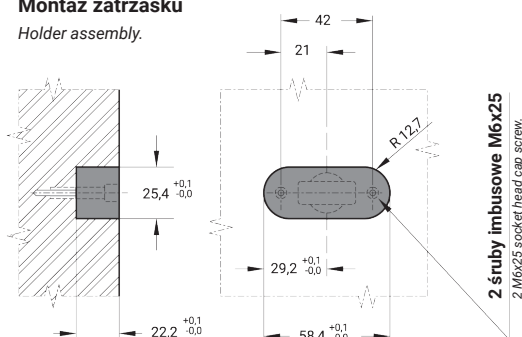

Montaż płytki ustalającej

Latch assembly.

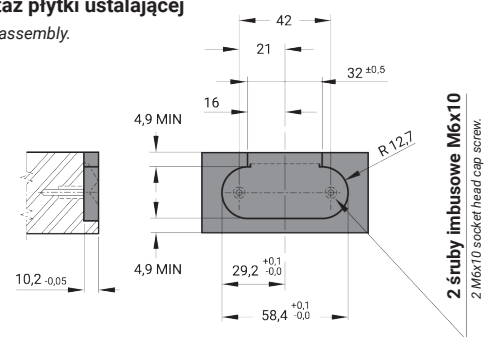

Płytki ustalające zatrzasku SLIDE-LOCK zazwyczaj montowana jest na suwaku formy, co nie jest regułą i projektant może przewidzieć inne rozwiązanie.

The latch is usually mounted into the slide because of normal space limitations and requirements. This is not a rule though, and the designer may locate the various components to best suit the application.

Zawór powietrzny

Air valve

VA

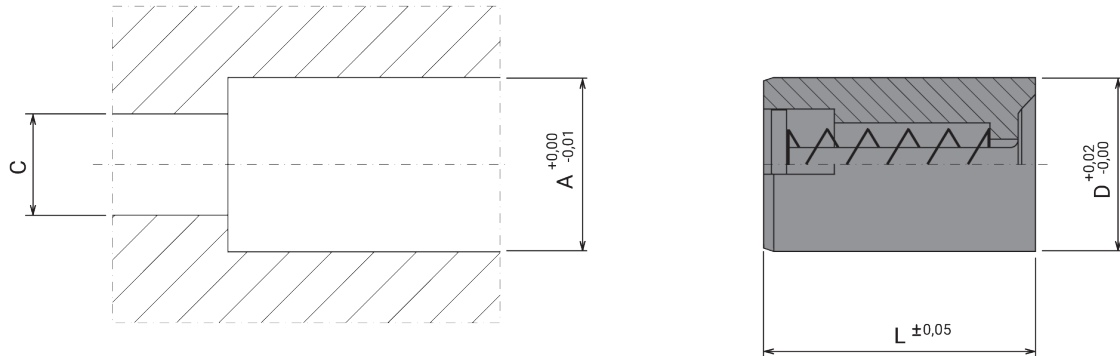

Przykłady instalacji
Examples of installation

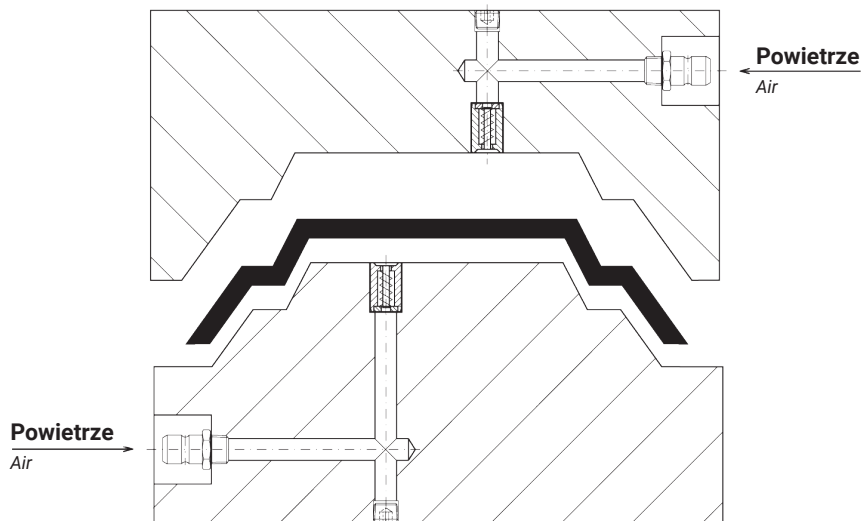

NR KAT.	D	L	A	C
VA-08	8	15	8	6
VA-10	10	20	10	8
VA-12	12	25	12	10
VA-16	16	30	16	14
VA-20	20	30	20	18
VA-25	25	30	25	23
VA-30	30	30	30	28

Licznik do form

Counterview®

CVPL-200

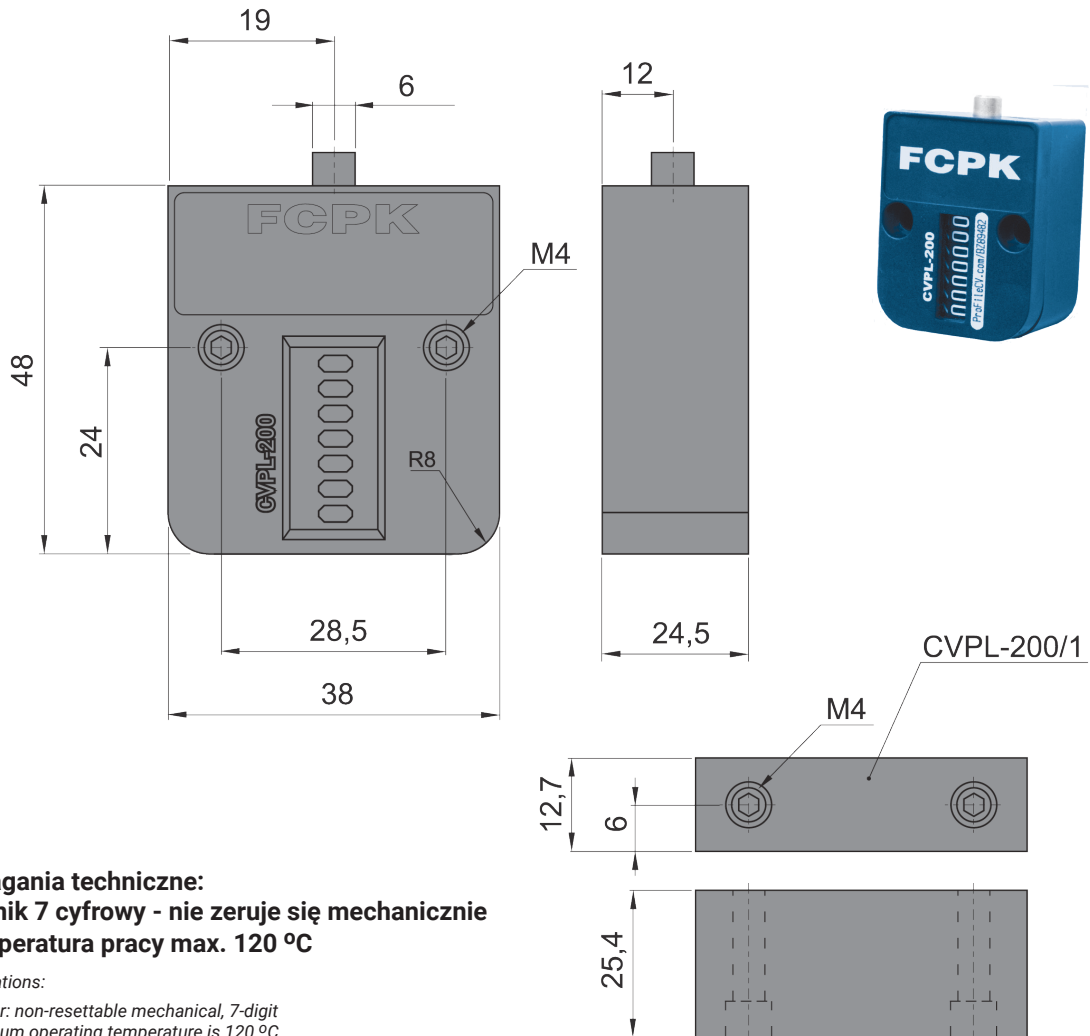

Wymagania techniczne:
 – licznik 7 cyfrowy - nie zeruje się mechanicznie
 – temperatura pracy max. 120 °C

Specifications:
 – counter: non-resettable mechanical, 7-digit
 – maximum operating temperature is 120 °C

Sposoby mocowania:

Method of mounting:

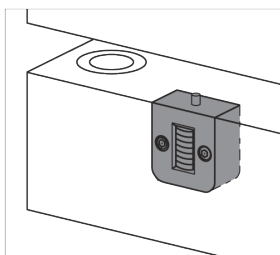

Mocowanie wewnętrzne
Internal Mount

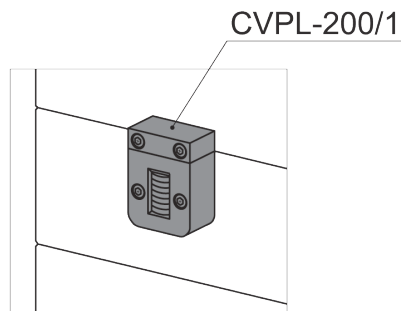

Mocowanie zewnętrzne
External Mount

